



HMD - Servo drive systems

■ Introduction

The AC servo motors of the HeiMotion Dynamic series meet the most demanding requirements for dynamics and robustness. The series is characterized by accurate torque gradings, voltage versions from 24 up to 400 V as well as very low cogging torques. Further advantages are the compactness and the high power density achieved by an optimized winding technology.

The HeiMotion Dynamic motors are available in two different flange sizes:

- 60 mm - HMD06
- 80 mm - HMD08

Overview of features:

- Low moment of inertia
- High efficiency
- High robustness
- Very compact design
- Very high power density
- Very low cogging torques
- Energy efficiency
- Very high acceleration values

■ Contents

General information

Overview motors	p. 4
Mating servo drive matrix	p. 6
Ambient conditions and technical characteristics	p. 8
Abbreviations and definitions	p. 9
Life span	p. 10
Order code	p. 11

HeiMotion Dynamic motors

HMD06-005	p. 12
HMD06-010	p. 16
HMD06-015	p. 20
HMD06-020	p. 24
HMD08-020	p. 28
HMD08-028	p. 32
HMD08-035	p. 36
HMD08-050	p. 40
HMD08-060	p. 44

Motor options

Configuration options	p. 46
Connection technology	p. 48
Standard Resolver	p. 50
Incremental encoders	p. 51
Absolute encoders EnDat 2.2	p. 52
Absolute encoders HIPERFACE®	p. 54
Absolute encoders HIPERFACE® DSL	p. 56
Hall encoders	p. 58
Holding brake	p. 60
Connector Y-Tec	p. 62
Connector M23	p. 64
Connectors for one cable solution	p. 66

Servo drives

HCD servo drive	p. 68
HCE servo drive	p. 70
HCF servo drive	p. 72
HCJ servo drive	p. 74

Overview

HeiMotion Dynamic motors basic performance values

Type	Model	U _{bus} [V _{DC}]	I _o [A]	I _n [A]	M _o [Nm]	M _n [Nm]	M _{max} [Nm]	n _n [rpm]	J [kg-cm ²]	P _n (S1) [W]
HMD06	HMD06-005	24	8.6	8.4	0.5	0.48	1.3	3,000	1.48E-01	150
		24	18.0	16.2	0.5	0.43	1.3	6,000	1.48E-01	250
		48	4.3	4.2	0.5	0.48	1.3	3,000	1.48E-01	150
		48	8.6	7.7	0.5	0.43	1.3	6,000	1.48E-01	250
		320	0.7	0.7	0.5	0.48	1.3	3,000	1.48E-01	150
		320	1.1	1.0	0.5	0.43	1.3	6,000	1.48E-01	250
		560	0.7	0.7	0.5	0.48	1.3	3,000	1.48E-01	150
		560	0.7	0.6	0.5	0.43	1.3	6,000	1.48E-01	250
	HMD06-010	24	18.9	13.6	1.0	0.72	2.5	3,000	2.00E-01	225
		24	34.2	21.9	1.0	0.61	2.5	6,000	2.00E-01	350
		48	8.9	6.5	1.0	0.72	2.5	3,000	2.00E-01	225
		48	17.7	11.8	1.0	0.61	2.5	6,000	2.00E-01	350
		320	1.2	0.9	1.0	0.72	2.5	3,000	2.00E-01	225
		320	2.3	1.4	1.0	0.61	2.5	6,000	2.00E-01	350
		560	0.9	0.7	1.0	0.72	2.5	3,000	2.00E-01	225
		560	1.2	0.7	1.0	0.61	2.5	6,000	2.00E-01	350
	HMD06-015	24	27.0	23.3	1.5	1.27	3.8	3,000	3.10E-01	400
		24	54.1	35.9	1.5	0.95	3.8	6,000	3.10E-01	550
		48	12.7	11.0	1.5	1.27	3.8	3,000	3.10E-01	400
		48	27.0	17.9	1.5	0.95	3.8	6,000	3.10E-01	550
		320	1.8	1.5	1.5	1.27	3.8	3,000	3.10E-01	400
		320	3.3	2.2	1.5	0.95	3.8	6,000	3.10E-01	550
		560	0.9	0.8	1.5	1.27	3.8	3,000	3.10E-01	400
		560	1.9	1.2	1.5	0.95	3.8	6,000	3.10E-01	550
	HMD06-020	24	32.0	28.4	2.0	1.75	5.0	3,000	4.50E-01	550
		24	63.8	46.5	2.0	1.39 *	5.0	6,000	4.50E-01	800
		48	17.5	15.5	2.0	1.75	5.0	3,000	4.50E-01	550
		48	32.0	23.3	2.0	1.39	5.0	6,000	4.50E-01	800
320		2.4	2.1	2.0	1.75	5.0	3,000	4.50E-01	550	
320		4.3	3.2	2.0	1.39	5.0	6,000	4.50E-01	800	
560		1.2	1.1	2.0	1.75	5.0	3,000	4.50E-01	550	
560		2.4	1.7	2.0	1.39	5.0	6,000	4.50E-01	800	

* If rated current > 30 A observe connection technology (p. 48) and encoder selection (p. 46)!

Type	Model	U _{bus} [V _{DC}]	I _o [A]	I _n [A]	M _o [Nm]	M _n [Nm]	M _{max} [Nm]	n _n [rpm]	J [kg-cm ²]	P _n (S1) [W]	
HMD08	HMD08-020	24	35.4	28.5	2.0	1.6	5.0	3,000	6.63E-01	500	
		24	58.5	39.5	2.0	1.3	5.0	5,500	6.63E-01	750	
		48	18.0	14.4	2.0	1.6	5.0	3,000	6.63E-01	500	
		48	35.4	23.8	2.0	1.3	5.0	5,500	6.63E-01	750	
		320	2.5	2.0	2.0	1.6	5.0	3,000	6.63E-01	500	
		320	4.5	3.0	2.0	1.3	5.0	5,500	6.63E-01	750	
		560	1.4	1.1	2.0	1.6	5.0	3,000	6.63E-01	500	
		560	2.5	1.7	2.0	1.3	5.0	5,500	6.63E-01	750	
		HMD08-028	24	47.7	41.3	2.8	2.4	7.0	3,000	9.30E-01	750
			24	110.6	69.9	2.8	1.7	7.0	5,500	9.30E-01	1,000
	48		25.5	22.2	2.8	2.4	7.0	3,000	9.30E-01	750	
	48		47.7	29.9	2.8	1.7	7.0	5,500	9.30E-01	1,000	
	320		3.4	2.9	2.8	2.4	7.0	3,000	9.30E-01	750	
	320		6.2	3.9	2.8	1.7	7.0	5,500	9.30E-01	1,000	
	560		1.9	1.7	2.8	2.4	7.0	3,000	9.30E-01	750	
	560		3.4	2.1	2.8	1.7	7.0	5,500	9.30E-01	1,000	
	HMD08-035		24	77.8	72.3	3.5	3.2	8.8	3,000	1.20E00	1,000
			24	103.7	64.9	3.5	2.1	8.8	5,500	1.20E00	1,200
		48	31.1	28.9	3.5	3.2	8.8	3,000	1.20E00	1,000	
		48	77.8	48.7	3.5	2.1	8.8	5,500	1.20E00	1,200	
		320	4.2	3.9	3.5	3.2	8.8	3,000	1.20E00	1,000	
		320	7.8	4.9	3.5	2.1	8.8	5,500	1.20E00	1,200	
		560	2.3	2.2	3.5	3.2	8.8	3,000	1.20E00	1,000	
		560	4.2	2.6	3.5	2.1	8.8	5,500	1.20E00	1,200	
		HMD08-050	24	98.7	96.5	5.0	4.8	12.5	3,000	1.73E00	1,500
			48	49.4	48.3	5.0	4.8	12.5	3,000	1.73E00	1,500
	48		98.7	60.0	5.0	2.9	12.5	5,500	1.73E00	1,650	
	320		6.2	6.1	5.0	4.8	12.5	3,000	1.73E00	1,500	
	320		11.0	6.7	5.0	2.9	12.5	5,500	1.73E00	1,650	
	560		3.3	3.3	5.0	4.8	12.5	3,000	1.73E00	1,500	
	560		6.2	3.8	5.0	2.9	12.5	5,500	1.73E00	1,650	
	HMD08-060		320	7.4	6.9	6.0	5.5	15.0	3,000	2.25E00	1,750
			320	12.1	7.4	6.0	3.4	15.0	5,500	2.25E00	1,950
			560	3.9	3.7	6.0	5.5	15.0	3,000	2.25E00	1,750
		560	7.4	4.5	6.0	3.4	15.0	5,500	2.25E00	1,950	

* If rated current > 30 A observe connection technology (p. 48) and encoder selection (p. 46)!

Overview

HeiMotion Dynamic motors mating servo drive matrix

Type	Model	n [rpm]	U _{bus} [V _{DC}]	HCD	HCE	HCE	HCF	HCJ	HCJ
				1 x 230 V _{AC}	1 x 230 V _{AC}	3 x 400 V _{AC}	24 - 48 V _{DC}	1 x 230 V _{AC}	3 x 400 V _{AC}
HMD06	HMD06-005	3,000	24						HCJ 24.012 *
		6,000	24						HCJ 24.016 **
		3,000	48	HCF 3000				HCJ 22.006 *	HCJ 24.007 *
		6,000	48	HCF 3000				HCJ 22.008 *	HCJ 24.012 *
		3,000	320		HCB 0.4 kW	HCE 0.375 kW		HCJ 22.003	
		6,000	320		HCB 0.4 kW	HCE 0.375 kW		HCJ 22.003	
		3,000	560				HCE 0.75 kW		HCJ 24.002
		6,000	560				HCE 0.75 kW		HCJ 24.002
	HMD06-010	3,000	24						HCJ 24.016 *
		6,000	24						HCJ 24.016 **
		3,000	48	HCF 3000				HCJ 22.008 *	HCJ 24.007 *
		6,000	48						HCJ 24.012 *
		3,000	320		HCB 0.4 kW	HCE 0.375 kW		HCJ 22.003	
		6,000	320		HCB 0.4 kW	HCE 0.375 kW		HCJ 22.003	
		3,000	560				HCE 0.75 kW		HCJ 24.002
		6,000	560				HCE 0.75 kW		HCJ 24.002
	HMD06-015	3,000	24						HCJ 24.016 **
		6,000	24						HCJ 24.016 **
		3,000	48						HCJ 24.012 *
		6,000	48						HCJ 24.016 **
		3,000	320		HCB 0.4 kW	HCE 0.375 kW		HCJ 22.003	
		6,000	320		HCB 0.75 kW	HCE 0.375 kW		HCJ 22.003	
		3,000	560				HCE 0.75 kW		HCJ 24.002
		6,000	560				HCE 0.75 kW		HCJ 24.002
	HMD06-020	3,000	24						HCJ 24.016 **
		6,000	24						HCJ 24.016 **
		3,000	48						HCJ 24.016 *
		6,000	48						HCJ 24.016 **
		3,000	320		HCB 0.75 kW	HCE 0.375 kW		HCJ 22.003	
		6,000	320		HCB 0.75 kW	HCE 0.75 kW		HCJ 22.006	
		3,000	560				HCE 0.75 kW		HCJ 24.002
		6,000	560				HCE 0.75 kW		HCJ 24.002

Type	Model	n [rpm]	U _{bus} [V _{DC}]	HCD	HCE	HCE	HCF	HCJ	HCJ	
				1 x 230 V _{AC}	1 x 230 V _{AC}	3 x 400 V _{AC}	24 - 48 V _{DC}	1 x 230 V _{AC}	3 x 400 V _{AC}	
HMD08	HMD08-020	3,000	24						HCJ 24.016 **	
		5,500	24						HCJ 24.016 **	
		3,000	48						HCJ 24.016 **	
		5,500	48						HCJ 24.016 **	
		3,000	320		HCB 0.4 kW	HCE 0.375 kW		HCJ 22.003		
		5,500	320		HCB 0.75 kW	HCE 0.75 kW		HCJ 22.003		
		3,000	560				HCE 0.75 kW		HCJ 24.002	
		5,500	560				HCE 0.75 kW		HCJ 24.002	
		HMD08-028	3,000	24						HCJ 24.016 **
			5,500	24						HCJ 24.016 **
			3,000	48						HCJ 24.016 **
			5,500	48						HCJ 24.016 **
	3,000		320		HCB 0.75 kW	HCE 0.75 kW		HCJ 22.003		
	5,500		320		HCB 1.0 kW	HCE 0.75 kW		HCJ 22.006		
	3,000		560				HCE 0.75 kW		HCJ 24.002	
	5,500		560				HCE 0.75 kW		HCJ 24.004	
	HMD08-035		3,000	24						HCJ 24.016 **
			5,500	24						HCJ 24.016 **
			3,000	48						HCJ 24.016 **
			5,500	48						HCJ 24.016 **
		3,000	320		HCB 1.0 kW	HCE 0.75 kW		HCJ 22.006		
		5,500	320			HCE 1.5 kW		HCJ 22.006		
		3,000	560				HCE 0.75 kW		HCJ 24.004	
		5,500	560				HCE 1.5 kW		HCJ 24.004	
		HMD08-050	3,000	24						HCJ 24.016 **
			3,000	48						HCJ 24.016 **
			5,500	48						HCJ 24.016 **
			3,000	320			HCE 1.5 kW		HCJ 22.008	
	5,500		320			HCE 1.5 kW		HCJ 22.008		
	3,000		560				HCE 1.5 kW		HCJ 24.004	
	5,500		560				HCE 1.5 kW		HCJ 24.007	
	HMD08-060		3,000	320			HCE 1.5 kW		HCJ 22.008	
			5,500	320					HCJ 22.008	
			3,000	560				HCE 1.5 kW		HCJ 24.007
			5,500	560				HCE 2.2 kW		HCJ 24.007



HCD
p. 68



HCE
p. 70



HCF
p. 72



HCJ
p. 74

* Power adapter necessary for power
** Power adapter necessary, derate

General information

Ambient conditions and technical characteristics

Motor type	Permanent magnet three-phase synchronous servo motor	
Ambient operating temperature	- 10 °C to + 40 °C	
Ambient storage temperature	- 20 °C to + 70 °C	
Humidity	< 90 % relative humidity (without condensation)	
Insulation class	F (155 °C) Δ T = 115 K	
Protection class	IP65 (standard version), (except drive end, protection class is IP21, without shaft oil seal)	
Cooling	Natural convective	
Bearing life	20,000 h under rated operation conditions (M_r)	
Temperature sensor	KTY84-130	
Voltage slew rate dU/dt	14 kV / μs	
Maximum altitude	4,000 meters above sealevel; derate 1% per 100 meters above 1,000 meters	
Concentricity, coaxiality and axial run-out	N (normal) per DIN 42955	
Vibration	Stage N in accordance to ISO 2373	
Cogging torque factor c_t	HMD06	< 2.0 % based on the stall torque (M_0)
	HMD08	< 1.5 % based on the stall torque (M_0)
Coating	Black top coat, RAL 9005	
Magnet material	Neodymium-Iron-Boron (NdFeB)	
Shaft end	Cylindrical shaft end with / without keyway	
Balancing quality	Q 2.5	
Encoder systems	Resolver, HIPERFACE®, HIPERFACE DSL®, Incremental encoder, SSI, EnDat 2.2	
Approvals	CE, - certification *	

* At the moment UL < 30 A allowed, at higher current please contact the sales department

Abbreviations and definitions

Abbr.	Unit	Explanation
f_n	[Hz]	Rated frequency
I_0	[A _{rms}]	Stall current per phase (motor current at stall torque M_0)
I_n	[A _{rms}]	Rated current (rated current per phase)
I_{max}	[A _{rms}]	Peak current (maximum permissible current per phase)
J	[kg-cm ²]	Moment of inertia rotor (motor without brake)
k_e	[V _{rms} / krpm]	Voltage constant (induced voltage between two phases at 1,000 rpm) rms (root mean square value)
k_t	[Nm / A _{rms}]	Theoretical torque constant (rms), without losses at 20 °C
L_{p-p}	[mH]	Winding inductance (2 phases) at rated current I_n
m	[kg]	Weight (motor without brake)
M_0	[Nm]	Stall torque (stall torque at S1)
M_n	[Nm]	Rated torque (continuous torque at S1)
M_{max}	[Nm]	Peak torque (maximum permissible torque for short periods)
n_n	[rpm]	Rated speed
n_{max}	[rpm]	Maximum speed
P_n	[W]	Rated power (mechanical power at the shaft)
R_{p-p}	[Ω]	Winding resistance (2 phases, at winding temperature of 20 °C)
c_t	[%]	Local cogging torque $c_t = \frac{M_{cmax} - M_{cmin}}{M_0} \times 100 \%$
M_{cmax}	[Nm]	Local maximum of the cogging torque
M_{cmin}	[Nm]	Local minimum of the cogging torque
T_{el}	[ms]	Electrical time constant
T_{th}	[min]	Thermal time constant
U_{mot}	[V _{rms}]	Rated motor voltage (2 phases at rated working point), rms
U_{bus}	[V _{DC}]	DC bus voltage

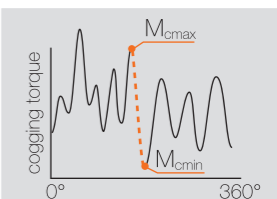

Life span

Shaft loading forces

Life span of the motors is at least 20,000 hours if operated under rated conditions. The table below shows admissible radial forces for the bearing load. Point of force application is in the middle of the shaft (see drawing).

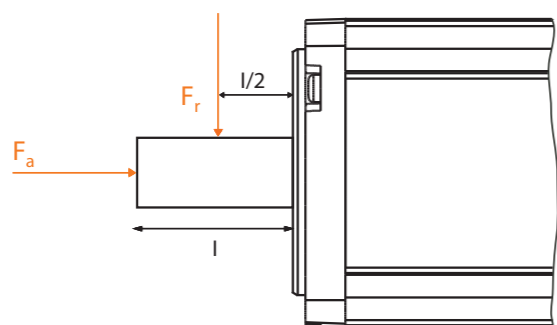

Maximum radial force $F_{r,}$ [N]

	1,000 [rpm]	2,000 [rpm]	3,000 [rpm]	4,000 [rpm]	5,000 [rpm]	6,000 [rpm]	7,000 [rpm]	8,000 [rpm]	9,000 [rpm]	10,000 [rpm]
HMD06-005	350	270	240	220	200	190	180	170	165	160
HMD06-010	360	290	250	230	210	200	190	180	175	170
HMD06-015	390	310	270	240	230	210	200	190	185	180
HMD06-020	400	320	280	260	240	220	210	200	195	190
HMD08-020	430	340	300	270	250	240	225	215	210	200
HMD08-028	460	370	320	290	270	250	240	230	220	210
HMD08-035	480	380	330	300	280	265	250	240	230	220
HMD08-050	510	410	360	320	300	280	270	260	250	240
HMD08-060	530	420	370	330	310	290	280	265	255	245

Maximum axial force: $F_a = 0.2 \times F_r$

At stall, a one-time axial force of 40 % of the radial force may be applied during motor mounting. Maximum allowed axial and radial forces must not occur together at the same time.

Order code

HMD08-028-320-30-B0H2MW23W

Frame/flange size	60 mm → 06 80 mm → 08	Options	Without brake 0XXXXXXXXX With brake BXXXXXXXXX Without feather key X0XXXXXXXX With feather key XPXXXXXXXX Resolver XXR1PXXXX Resolver safely mounted XXRAPXXXX HES 1 (4.5 V _{pp}) XXM1SXXXX HES 1 (1.0 V _{pp}) XXM2SXXXX HEM 1 (1.0 V _{pp} without battery) XXM1MXXXX HEM 1 (1.0 V _{pp} with battery) XXM2MXXXX HES 3 XXM1IXXXX ECI 1118 XXE1SXXXX EQI 1131 XXE1MXXXX SEK 37 XXH1SXXXX SEL 37 XXH1MXXXX SKS 36 XXH2SXXXX SKS 36S safely mounted XXHBSXXXX SKM 36 XXH2MXXXX SKM 36S safely mounted XXHBMXXXX SRS 50 XXH3SXXXX SRM 50 XXH3MXXXX EES 37 XXD1SXXXX EES 37-2 safely mounted ²⁾ XXDASXXXX EEM 37 XXD1MXXXX EEM 37-2 safely mounted ²⁾ XXDAMXXXX EKS 36 XXD2SXXXX EKS 36-2 safely mounted XXDBSXXXX EKM 36 XXD2MXXXX EKM 36-2 safely mounted XXDBMXXXX EFS 50 XXD3SXXXX EFM 50 XXD3MXXXX CKS 36 XXI1SXXXX M23 angled XXXXXW23X Y-Tec XXXXXY17X I-Tec XXXXXI17X Cable outlet 1.5m ¹⁾ XXXXXK15X Cable outlet 5m ¹⁾ XXXXXK50X Twintus XXXXXT16X Without radial shaft seal XXXXXXXX0 With radial shaft seal XXXXXXXXW
Stall torque	0.5 Nm → 005 1.0 Nm → 010 1.5 Nm → 015 2.0 Nm → 020 2.8 Nm → 028 3.5 Nm → 035 5.0 Nm → 050 6.0 Nm → 060		
DC bus voltage	24 V → 024 48 V → 048 320 V → 320 560 V → 560		
Rated speed	3,000 rpm → 30 5,500 rpm → 55 6,000 rpm → 60		

1) Upon request
2) In preparation

Example: HMD08-028-320-30-B0H2MW23W

Frame/flange size 80 mm	Options:
Stall torque 2.8 Nm	With brake
DC bus voltage 320 V	Without feather key
Rated speed 3,000 rpm	Encoder SKM 36
	Angled connector M23
	With radial shaft seal

HMD06-005

24 / 48 V

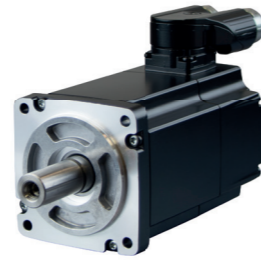

Specifications

	HMD06-005				
Rated speed [rpm]	n_n	3,000	6,000	3,000	6,000
Number of pole pairs		3	3	3	3
Wiring of the motor winding		Y	Y	Y	Y
DC bus voltage [V _{DC}]	U_{bus}	24	24	48	48
Rated voltage motor [V _{ms}]	U_{mot}	13	12	26	24
Rated power [W]	P_n	150	250	150	250
Rated torque [Nm]	M_n	0.48	0.43	0.48	0.43
Rated current per phase [A _{rms}]	I_n	8.4	16.2	4.2	7.7
Stall torque [Nm]	M_0	0.5	0.5	0.5	0.5
Stall current per phase [A _{rms}]	I_0	8.6	18.0	4.3	8.6
Peak torque [Nm]	M_{max}	1.3	1.3	1.3	1.3
Peak current [A _{rms}]	I_{max}	21.4	45.0	10.8	21.5
Maximum speed [rpm]	n_{max}	4,195	8,855	4,140	8,390
Voltage constant at 1,000 rpm [V _{ms}]	k_e	3.8	1.8	7.7	3.8
Torque constant [Nm / A _{rms}]	k_t	0.06	0.03	0.13	0.06
Winding resistance (2 phases) at 20 °C [Ω]	R_{p-p}	0.24	0.06	0.87	0.24
Winding inductance (2 phases) [mH]	L_{p-p}	0.48	0.11	1.90	0.48
Electrical time constant [ms]	t_{el}	2.0	1.8	2.2	2.0
Thermal time constant [min]	t_{th}	25	25	25	25
Moment of inertia rotor [kg·cm ²]	J	1.48E-01	1.48E-01	1.48E-01	1.48E-01
Weight of motor [kg]	m	1.1	1.1	1.1	1.1

For standstill / rated current greater than 30 A, observe connection technology (Page 48) and encoder selection (Page 46)!
Other voltage variants available on request.

Performance

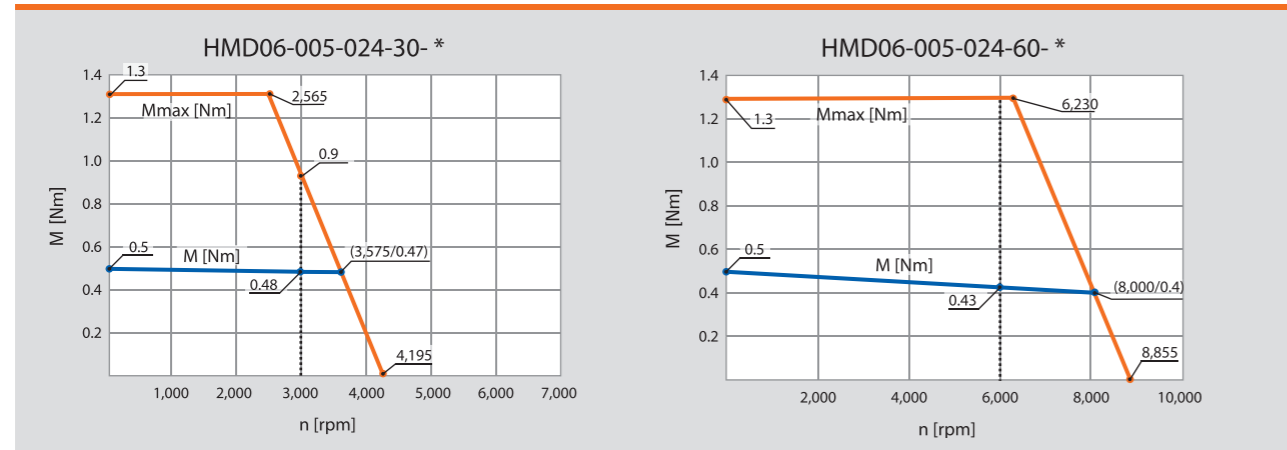

Dimensions

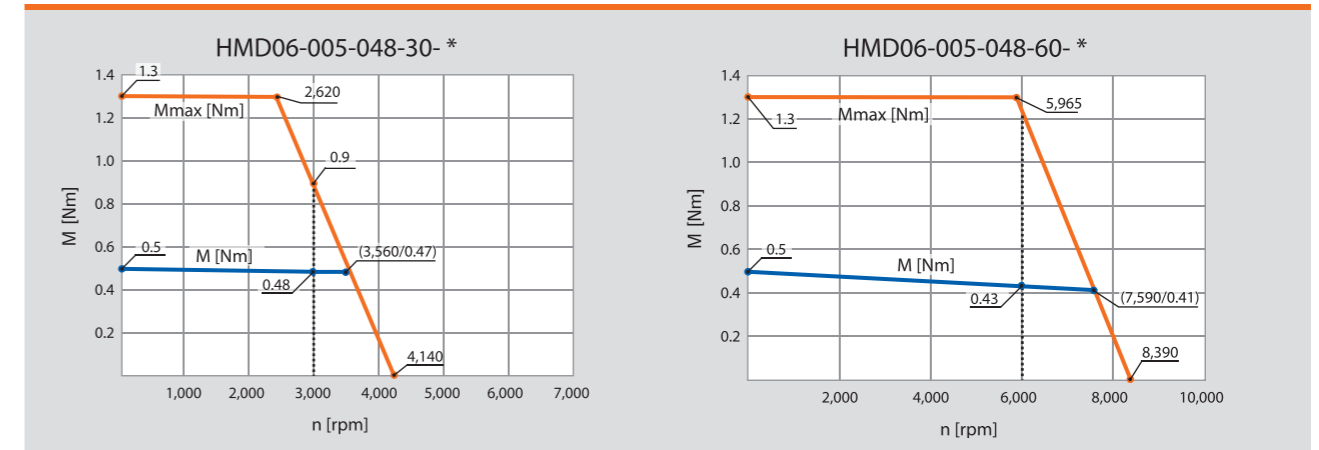
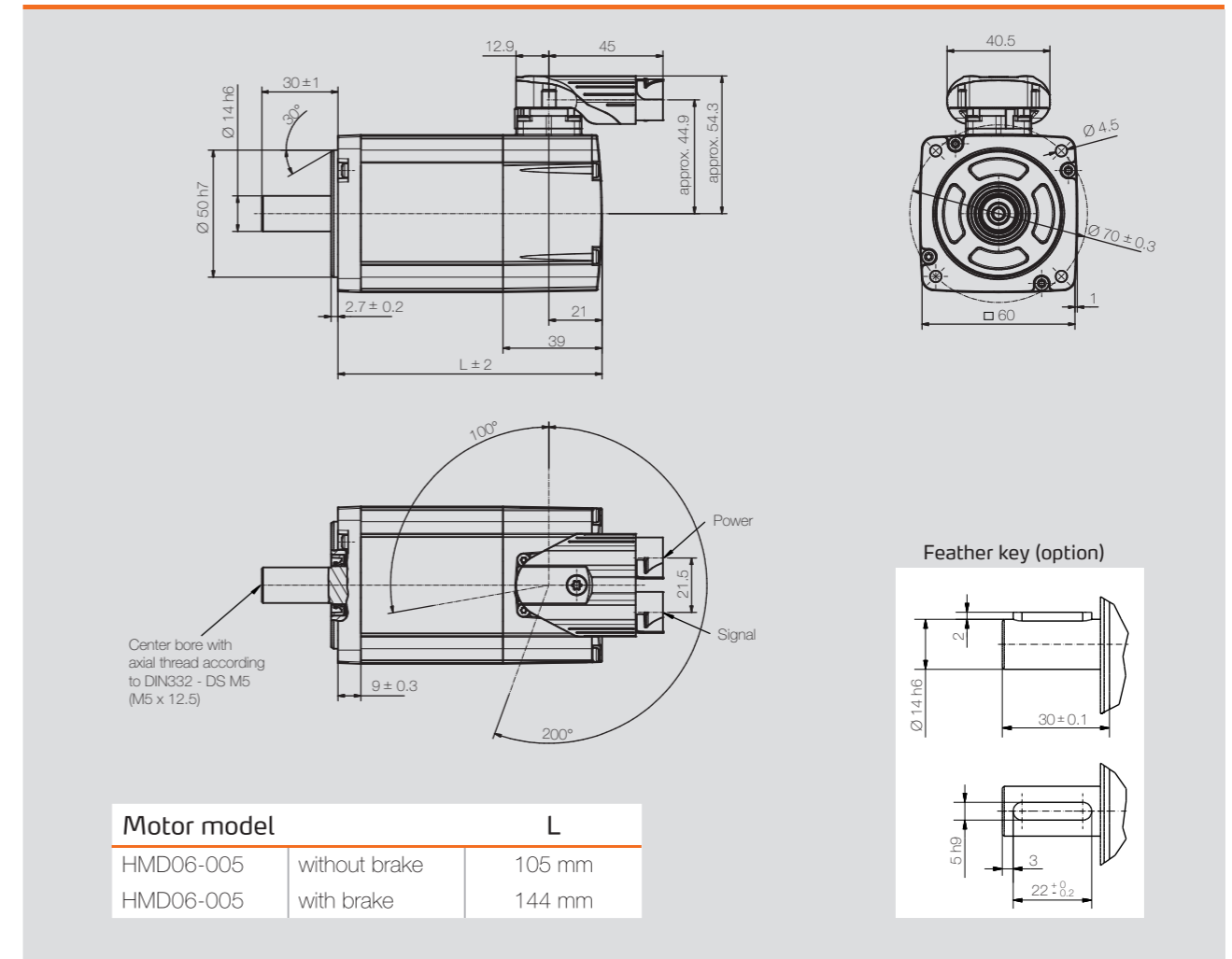

HMD06-005

320 / 560 V



Specifications

	HMD06-005				
Rated speed [rpm]	n_n	3,000	6,000	3,000	6,000
Number of pole pairs		3	3	3	3
Wiring of the motor winding		Y	Y	Y	Y
DC bus voltage [V _{DC}]	U_{bus}	320	320	560	560
Rated voltage motor [V _{rms}]	U_{mot}	167	199	167	309
Rated power [W]	P_n	150	250	150	250
Rated torque [Nm]	M_n	0.48	0.43	0.48	0.43
Rated current per phase [A _{rms}]	I_n	0.7	1.0	0.7	0.6
Stall torque [Nm]	M_0	0.5	0.5	0.5	0.5
Stall current per phase [A _{rms}]	I_0	0.7	1.1	0.7	0.7
Peak torque [Nm]	M_{max}	1.3	1.3	1.3	1.3
Peak current [A _{rms}]	I_{max}	1.7	2.6	1.7	1.7
Maximum speed [rpm]	n_{max}	4,365	7,200	7,590	7,590
Voltage constant at 1,000 rpm [V _{rms}]	k_e	48.4	31.0	48.4	48.4
Torque constant [Nm / A _{rms}]	k_t	0.73	0.51	0.73	0.7
Winding resistance (2 phases) at 20 °C [Ω]	R_{p-p}	39.9	17.6	39.9	39.9
Winding inductance (2 phases) [mH]	L_{p-p}	75.9	31.6	75.9	75.9
Electrical time constant [ms]	t_{el}	1.9	1.8	1.9	1.9
Thermal time constant [min]	t_{th}	25	25	25	25
Moment of inertia rotor [kg·cm ²]	J	1.48E-01	1.48E-01	1.48E-01	1.48E-01
Weight of motor [kg]	m	1.1	1.1	1.1	1.1

For standstill / rated current greater than 30 A, observe connection technology (Page 48) and encoder selection (Page 46)!
Other voltage variants available on request.

Performance

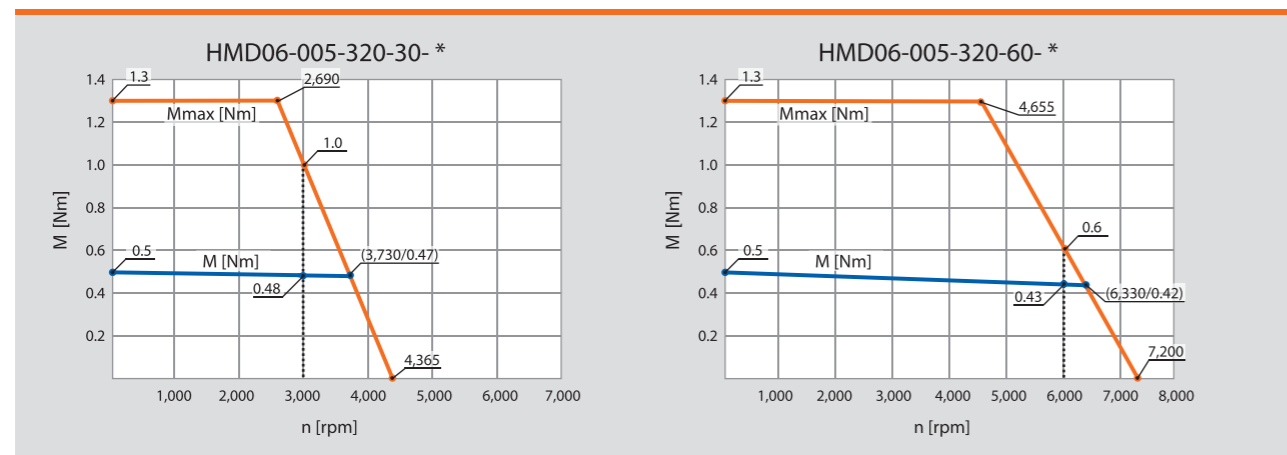

Dimensions

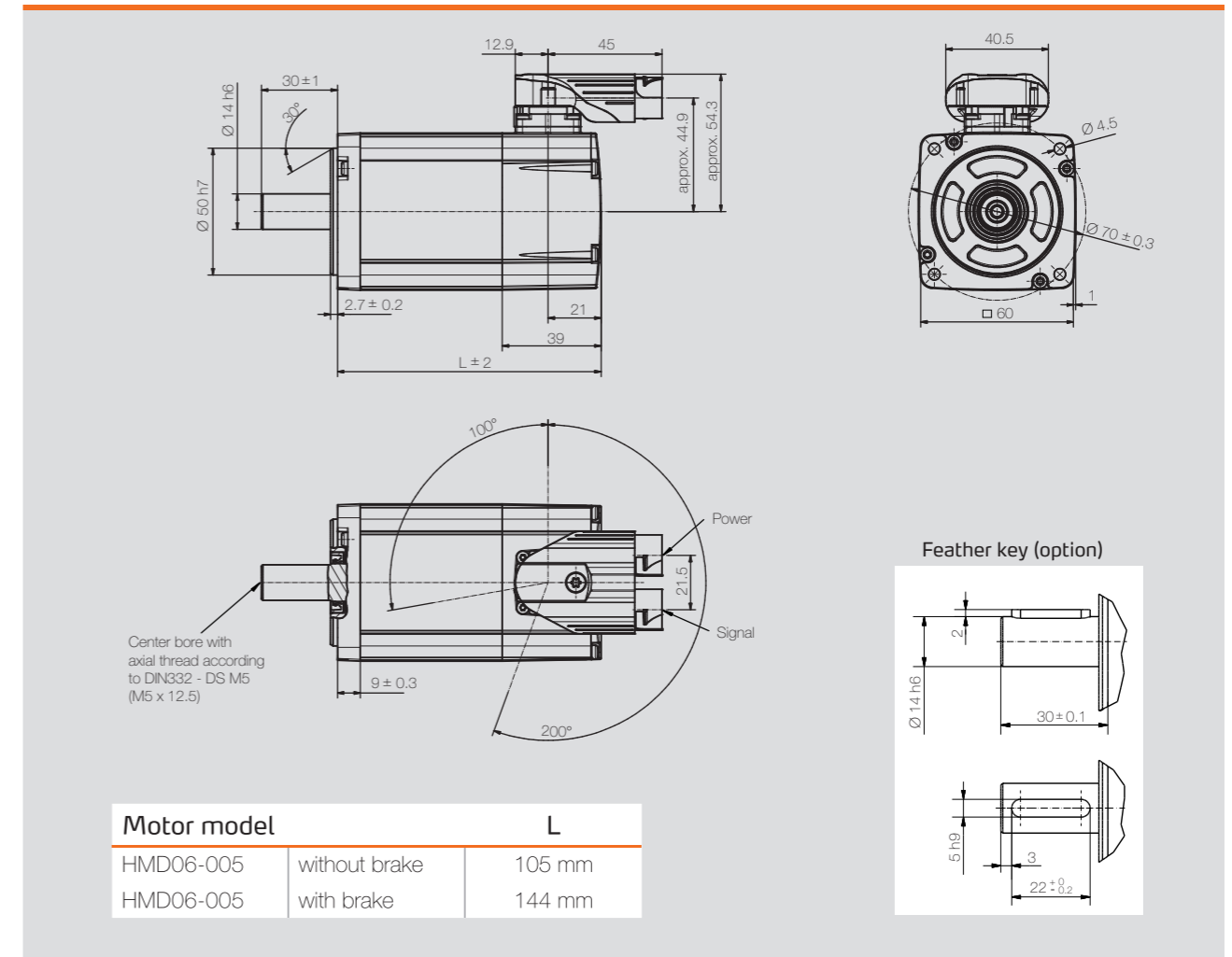

HMD06-010

24 / 48 V

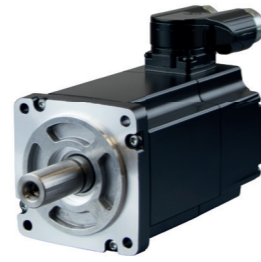

Specifications

	HMD06-010				
Rated speed [rpm]	n_n	3,000	6,000	3,000	6,000
Number of pole pairs		3	3	3	3
Wiring of the motor winding		Y	Y	Y	Y
DC bus voltage [V _{DC}]	U_{bus}	24	24	48	48
Rated voltage motor [V _{rms}]	U_{mot}	12	12	25	22
Rated power [W]	P_n	225	350	225	350
Rated torque [Nm]	M_n	0.72	0.61	0.72	0.61
Rated current per phase [A _{rms}]	I_n	13.6	21.9	6.5	11.8
Stall torque [Nm]	M_0	1.0	1.0	1.0	1.0
Stall current per phase [A _{rms}]	I_0	18.9	34.2	8.9	17.7
Peak torque [Nm]	M_{max}	2.5	2.5	2.5	2.5
Peak current [A _{rms}]	I_{max}	47.3	85.5	22.3	44.3
Maximum speed [rpm]	n_{max}	4,425	8,400	4,310	8,445
Voltage constant at 1,000 rpm [V _{rms}]	k_e	3.6	1.9	7.4	3.5
Torque constant [Nm / A _{rms}]	k_t	0.06	0.03	0.12	0.06
Winding resistance (2 phases) at 20 °C [Ω]	R_{p-p}	0.14	0.04	0.5	0.14
Winding inductance (2 phases) [mH]	L_{p-p}	0.27	0.08	1.17	0.27
Electrical time constant [ms]	t_{el}	2.0	2.2	2.3	2.0
Thermal time constant [min]	t_{th}	25	25	25	25
Moment of inertia rotor [kg·cm ²]	J	2.00E-01	2.00E-01	2.00E-01	2.00E-01
Weight of motor [kg]	m	1.3	1.3	1.3	1.3

Dimensions

Technical drawings showing dimensions for the motor. Key dimensions include: shaft diameter $\varnothing 50\text{ h7}$, mounting flange diameter $\varnothing 70 \pm 0.3$, and overall length $L \pm 2$. The drawings also show the location of the power and signal connections and the feather key option.

Motor model	L
HMD06-010 without brake	115 mm
HMD06-010 with brake	154 mm

Performance

For standstill / rated current greater than 30 A, observe connection technology (Page 48) and encoder selection (Page 46)!
Other voltage variants available on request.

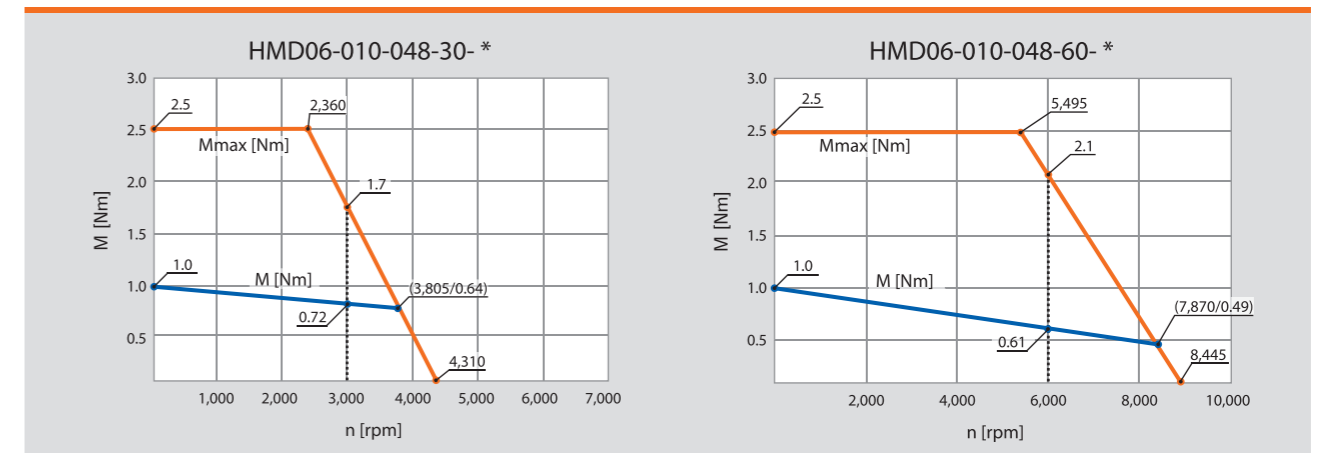
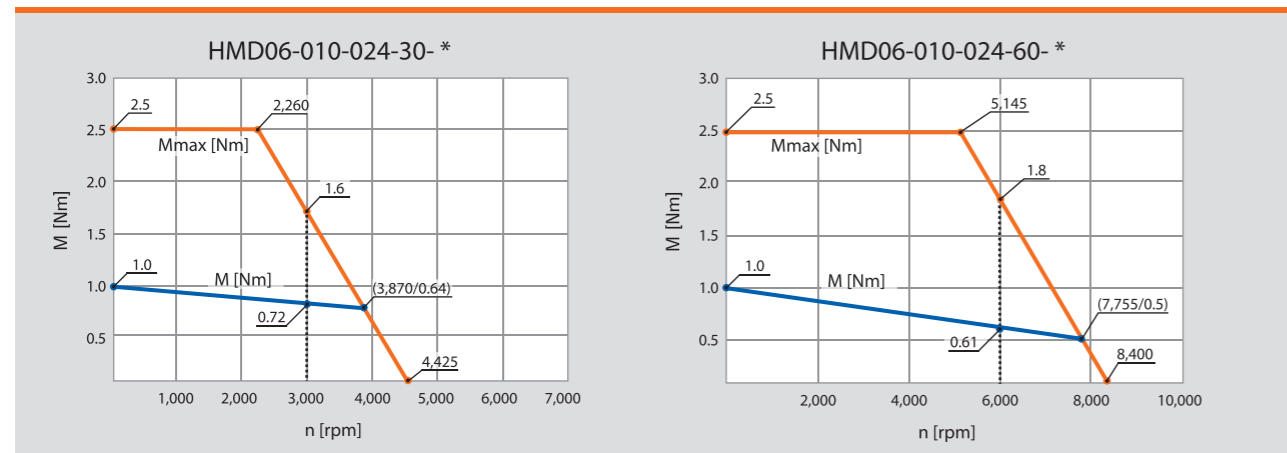

HMD06-010

320 / 560 V



Specifications

	HMD06-010				
Rated speed [rpm]	n_n	3,000	6,000	3,000	6,000
Number of pole pairs		3	3	3	3
Wiring of the motor winding		Y	Y	Y	Y
DC bus voltage [V _{DC}]	U_{bus}	320	320	560	560
Rated voltage motor [V _{rms}]	U_{mot}	189	189	244	351
Rated power [W]	P_n	225	350	225	350
Rated torque [Nm]	M_n	0.72	0.61	0.72	0.61
Rated current per phase [A _{rms}]	I_n	0.9	1.4	0.7	0.7
Stall torque [Nm]	M_0	1.0	1.0	1.0	1.0
Stall current per phase [A _{rms}]	I_0	1.2	2.3	0.9	1.2
Peak torque [Nm]	M_{max}	2.5	2.5	2.5	2.5
Peak current [A _{rms}]	I_{max}	2.9	5.8	2.3	2.9
Maximum speed [rpm]	n_{max}	3,780	7,090	5,080	6,900
Voltage constant at 1,000 rpm [V _{rms}]	k_e	55.9	29.8	72.3	55.9
Torque constant [Nm / A _{rms}]	k_t	0.93	0.49	1.09	0.93
Winding resistance (2 phases) at 20 °C [Ω]	R_{p-p}	31.30	9.40	51.1	31.3
Winding inductance (2 phases) [mH]	L_{p-p}	67.6	19.8	113.0	67.6
Electrical time constant [ms]	t_{el}	2.2	2.1	2.2	2.2
Thermal time constant [min]	t_{th}	25	25	25	25
Moment of inertia rotor [kg·cm ²]	J	2.00E-01	2.00E-01	2.00E-01	2.00E-01
Weight of motor [kg]	m	1.3	1.3	1.3	1.3

Dimensions

Center bore with axial thread according to DIN332 - DS M5 (M5 x 12.5)

Power

Signal

Feather key (option)

Motor model	L
HMD06-010 without brake	115 mm
HMD06-010 with brake	154 mm

Performance

For standstill / rated current greater than 30 A, observe connection technology (Page 48) and encoder selection (Page 46)!
Other voltage variants available on request.

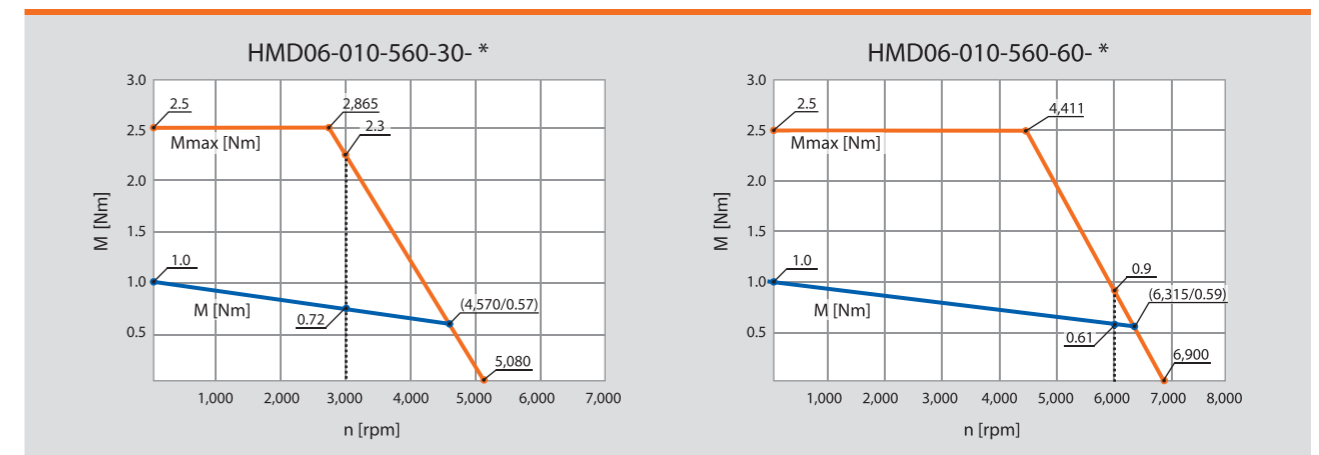
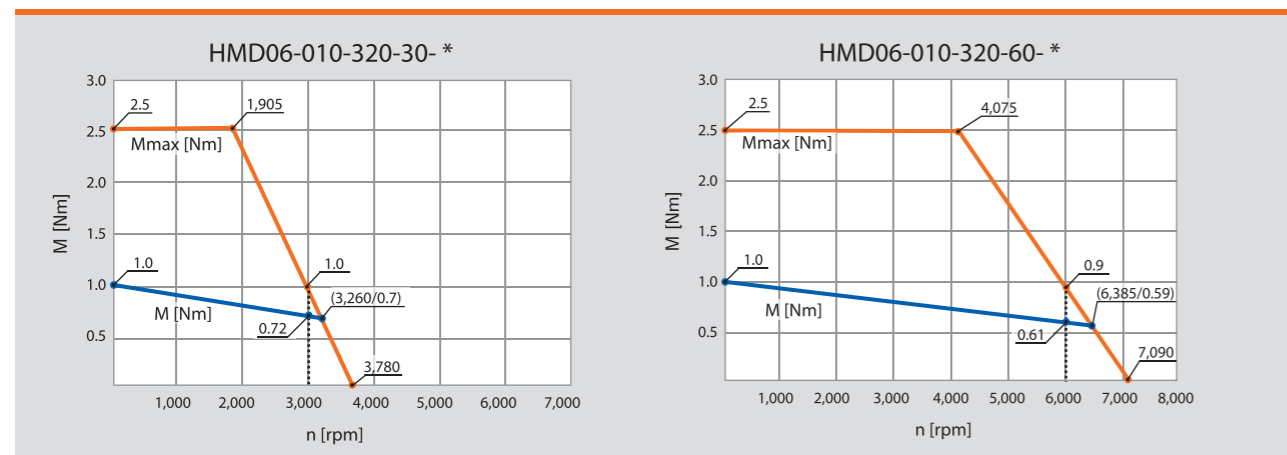

HMD06-015

24 / 48 V

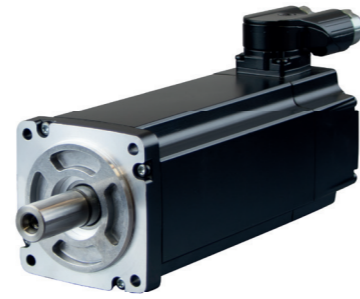

Specifications

	HMD06-015				
Rated speed [rpm]	n_n	3,000	6,000	3,000	6,000
Number of pole pairs		3	3	3	3
Wiring of the motor winding		Y	Y	Y	Y
DC bus voltage [V _{DC}]	U_{bus}	24	24	48	48
Rated voltage motor [V _{rms}]	U_{mot}	12	11	26	22
Rated power [W]	P_n	400	550	400	550
Rated torque [Nm]	M_n	1.27	0.95	1.27	0.95
Rated current per phase [A _{rms}]	I_n	23.3	35.9	11.0	17.9
Stall torque [Nm]	M_0	1.5	1.5	1.5	1.5
Stall current per phase [A _{rms}]	I_0	27.0	54.1	12.7	27.0
Peak torque [Nm]	M_{max}	3.8	3.8	3.8	3.8
Peak current [A _{rms}]	I_{max}	67.5	135.3	31.8	67.5
Maximum speed [rpm]	n_{max}	4,425	8,855	4,140	8,855
Voltage constant at 1,000 rpm [V _{rms}]	k_e	3.6	1.8	7.7	3.6
Torque constant [Nm / A _{rms}]	k_t	0.06	0.03	0.13	0.06
Winding resistance (2 phases) at 20 °C [Ω]	R_{p-p}	0.07	0.02	0.32	0.07
Winding inductance (2 phases) [mH]	L_{p-p}	0.17	0.04	0.76	0.17
Electrical time constant [ms]	t_{el}	2.4	2.7	2.4	2.4
Thermal time constant [min]	t_{th}	25	25	25	25
Moment of inertia rotor [kg-cm ²]	J	3.10E-01	3.10E-01	3.10E-01	3.10E-01
Weight of motor [kg]	m	1.6	1.6	1.6	1.6

Dimensions

Center bore with axial thread according to DIN332 - DS M5 (M5 x 12.5)

Motor model	L	
HMD06-015 without brake	135 mm	
HMD06-015 with brake	174 mm	

Feather key (option)

For standstill / rated current greater than 30 A, observe connection technology (Page 48) and encoder selection (Page 46)!
Other voltage variants available on request.

Performance

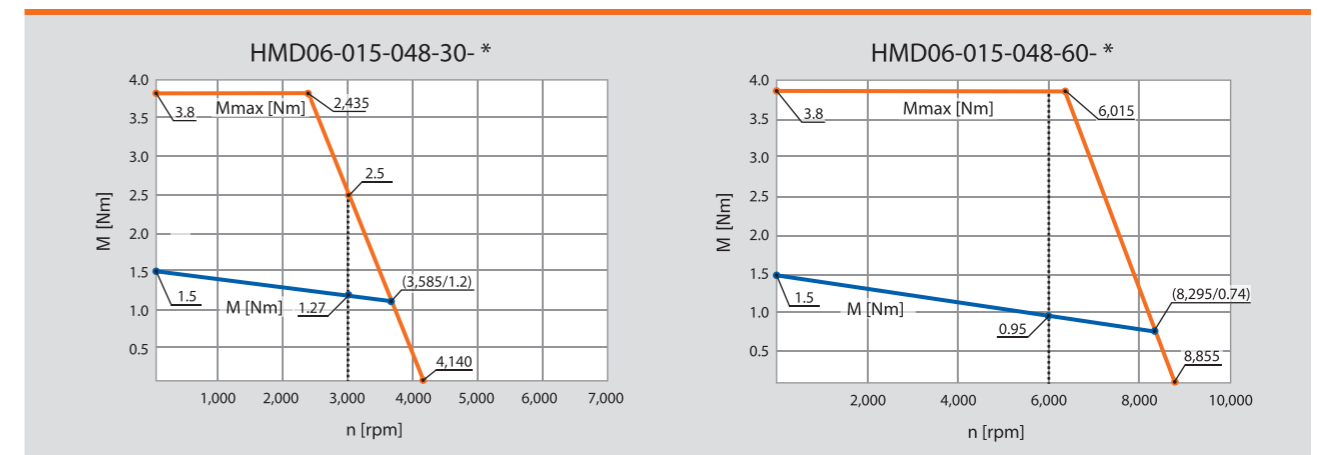
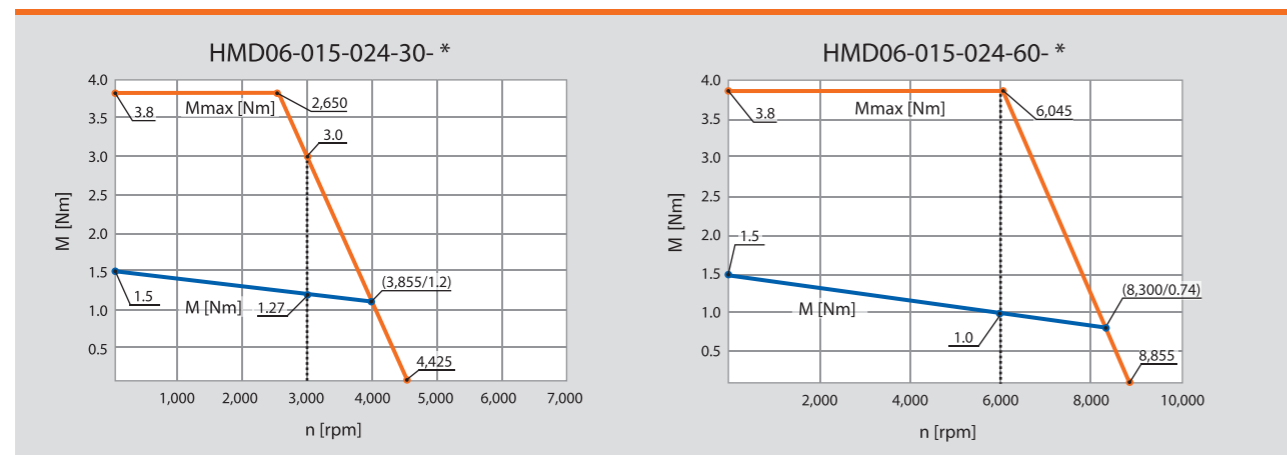

HMD06-015

320 / 560 V

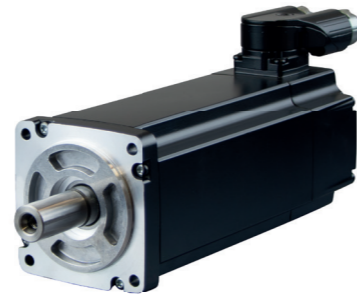

Specifications

	HMD06-015				
Rated speed [rpm]	n_n	3,000	6,000	3,000	6,000
Number of pole pairs		3	3	3	3
Wiring of the motor winding		Y	Y	Y	Y
DC bus voltage [V _{DC}]	U_{bus}	320	320	560	560
Rated voltage motor [V _{rms}]	U_{mot}	187	184	358	345
Rated power [W]	P_n	400	550	400	550
Rated torque [Nm]	M_n	1.27	0.95	1.27	0.95
Rated current per phase [A _{rms}]	I_n	1.5	2.2	0.8	1.2
Stall torque [Nm]	M_0	1.5	1.5	1.5	1.5
Stall current per phase [A _{rms}]	I_0	1.8	3.3	0.9	1.9
Peak torque [Nm]	M_{max}	3.8	3.8	3.8	3.8
Peak current [A _{rms}]	I_{max}	4.4	8.3	2.3	4.7
Maximum speed [rpm]	n_{max}	3,790	7,140	3,600	6,900
Voltage constant at 1,000 rpm [V _{rms}]	k_e	55.8	29.6	107.1	55.8
Torque constant [Nm / A _{rms}]	k_t	0.92	0.49	1.77	0.92
Winding resistance (2 phases) at 20 °C [Ω]	R_{p-p}	16.80	4.00	57.8	16.8
Winding inductance (2 phases) [mH]	L_{p-p}	40.0	11.8	147.2	40.0
Electrical time constant [ms]	t_{el}	2.4	3.0	2.5	2.4
Thermal time constant [min]	t_{th}	25	25	25	25
Moment of inertia rotor [kg·cm ²]	J	3.10E-01	3.10E-01	3.10E-01	3.10E-01
Weight of motor [kg]	m	1.6	1.6	1.6	1.6

For standstill / rated current greater than 30 A, observe connection technology (Page 48) and encoder selection (Page 46)!
Other voltage variants available on request.

Performance

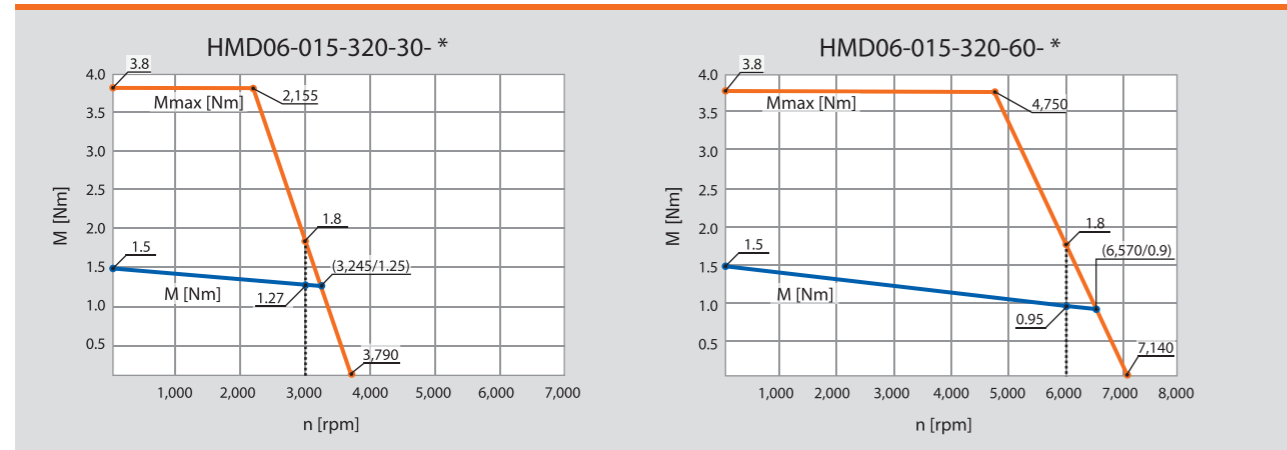

Dimensions

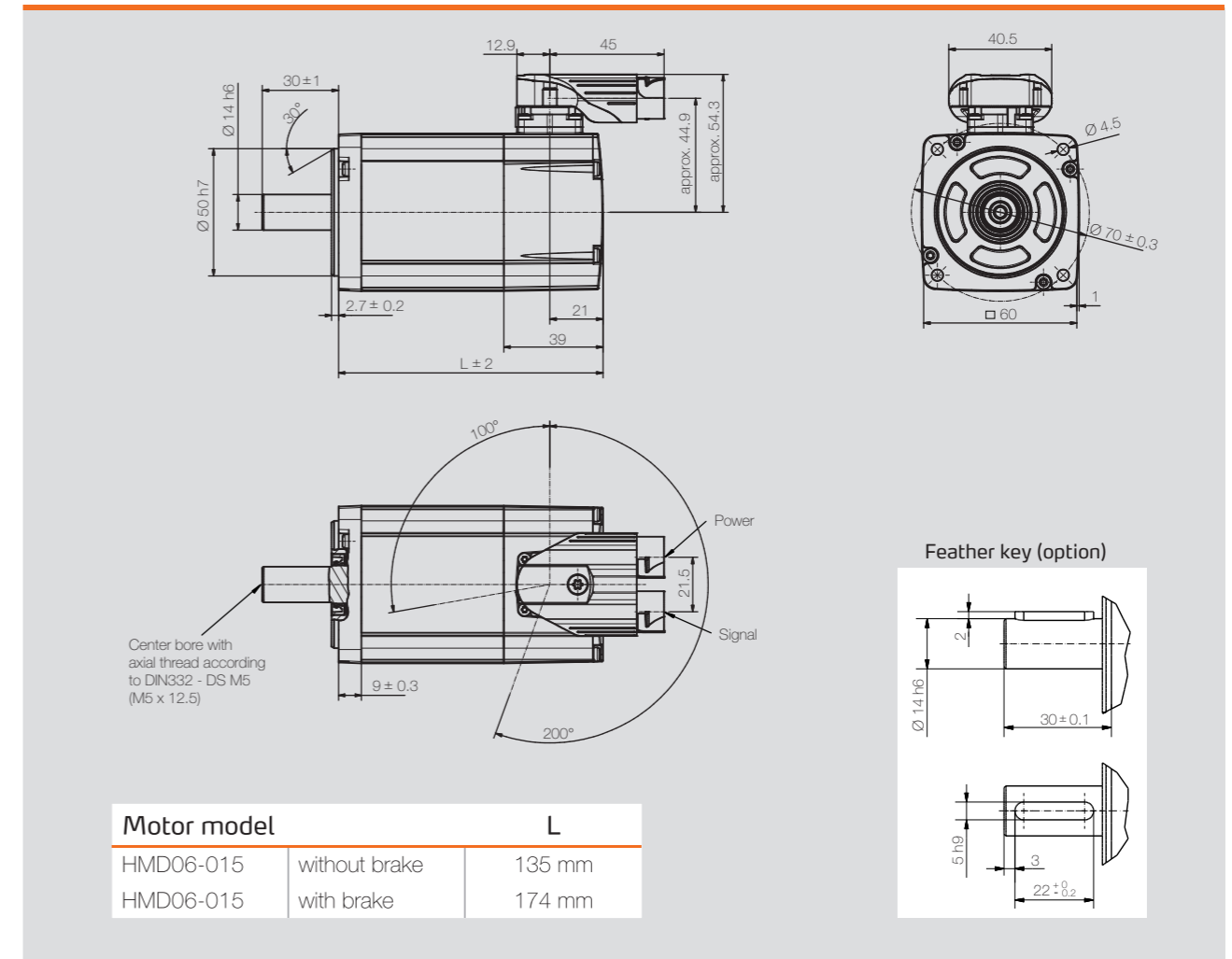

HMD06-020

24 / 48 V

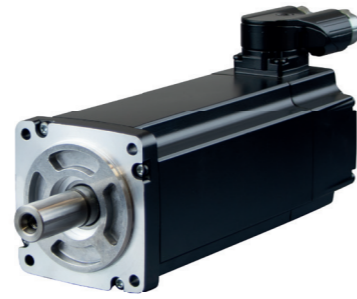

Specifications

	HMD06-020				
Rated speed [rpm]	n_n	3,000	6,000	3,000	6,000
Number of pole pairs		3	3	3	3
Wiring of the motor winding		Y	Y	Y	Y
DC bus voltage [V _{DC}]	U_{bus}	24	24	48	48
Rated voltage motor [V _{rms}]	U_{mot}	13	13	25	25
Rated power [W]	P_n	550	800	550	800
Rated torque [Nm]	M_n	1.75	1.39	1.75	1.39
Rated current per phase [A _{rms}]	I_n	28.4	46.5	15.5	23.3
Stall torque [Nm]	M_0	2.0	2.0	2.0	2.0
Stall current per phase [A _{rms}]	I_0	32.0	63.8	17.5	32.0
Peak torque [Nm]	M_{max}	5.0	5.0	5.0	5.0
Peak current [A _{rms}]	I_{max}	80.0	159.5	43.8	80.0
Maximum speed [rpm]	n_{max}	3,885	7,970	4,250	7,775
Voltage constant at 1,000 rpm [V _{rms}]	k_e	4.1	2.0	7.5	4.1
Torque constant [Nm / A _{rms}]	k_t	0.07	0.03	0.12	0.07
Winding resistance (2 phases) at 20 °C [Ω]	R_{p-p}	0.06	0.01	0.19	0.06
Winding inductance (2 phases) [mH]	L_{p-p}	0.14	0.04	0.49	0.14
Electrical time constant [ms]	t_{el}	2.6	2.8	2.6	2.6
Thermal time constant [min]	t_{th}	25	25	25	25
Moment of inertia rotor [kg·cm ²]	J	4.50E-01	4.50E-01	4.50E-01	4.50E-01
Weight of motor [kg]	m	2.0	2.0	2.0	2.0

Dimensions

Technical drawings showing dimensions for the HMD06-020 motor. Key dimensions include: shaft diameter $\varnothing 50\text{ h7}$, mounting flange diameter $\varnothing 70 \pm 0.3$, and overall length $L \pm 2$. The drawings also show the location of the power and signal connections and the feather key option.

Motor model	L	
HMD06-020 without brake	160 mm	
HMD06-020 with brake	199 mm	

Performance

For standstill / rated current greater than 30 A, observe connection technology (Page 48) and encoder selection (Page 46)!
Other voltage variants available on request.

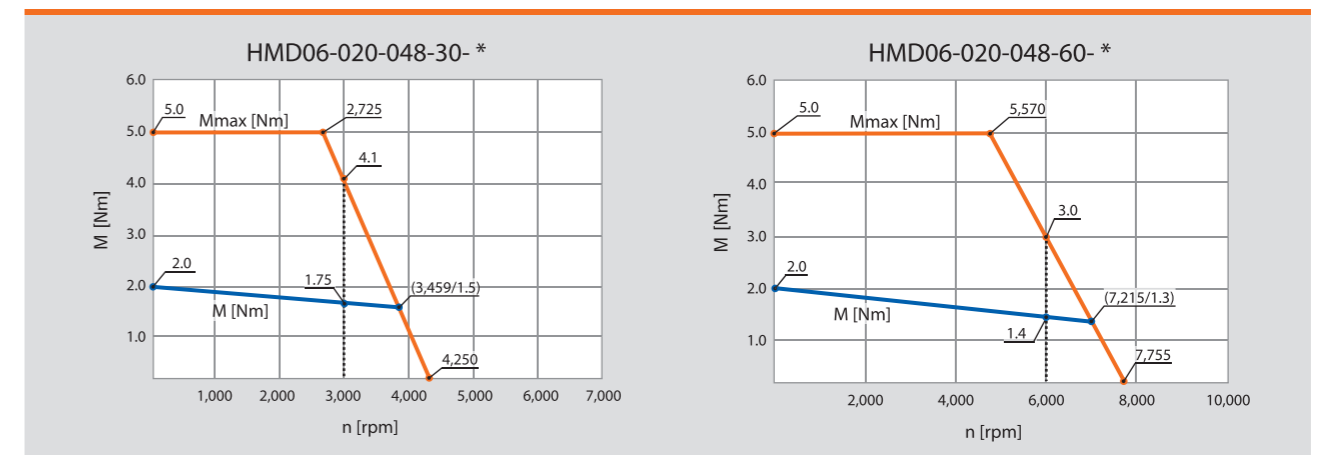
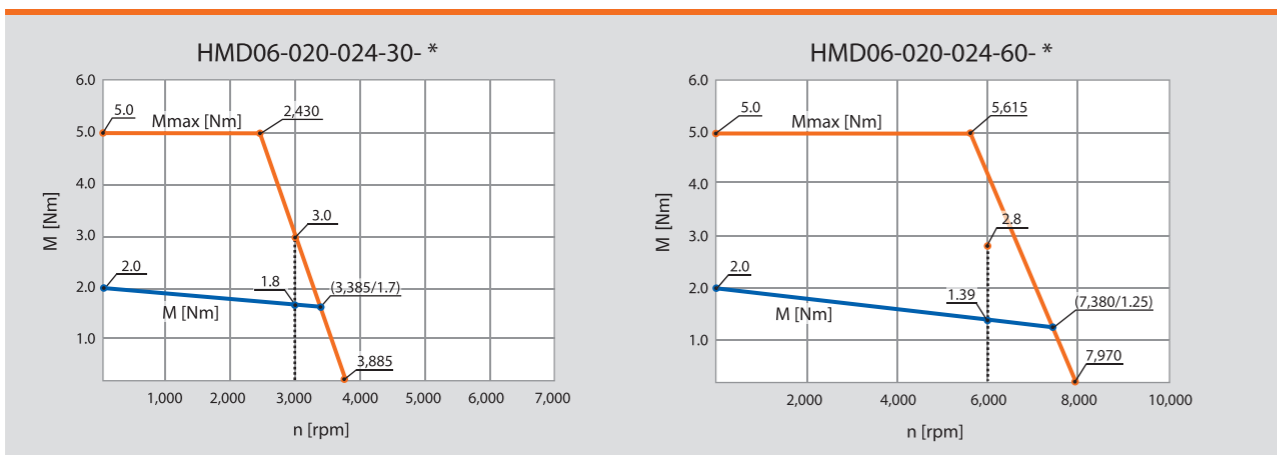

HMD06-020

320 / 560 V

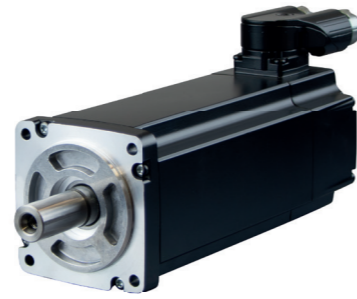

Specifications

	HMD06-020				
Rated speed [rpm]	n_n	3,000	6,000	3,000	6,000
Number of pole pairs		3	3	3	3
Wiring of the motor winding		Y	Y	Y	Y
DC bus voltage [V _{DC}]	U_{bus}	320	320	560	560
Rated voltage motor [V _{rms}]	U_{mot}	182	184	353	343
Rated power [W]	P_n	550	800	550	800
Rated torque [Nm]	M_n	1.75	1.39	1.75	1.39
Rated current per phase [A _{rms}]	I_n	2.1	3.2	1.1	1.7
Stall torque [Nm]	M_0	2.0	2.0	2.0	2.0
Stall current per phase [A _{rms}]	I_0	2.4	4.3	1.2	2.4
Peak torque [Nm]	M_{max}	5.0	5.0	5.0	5.0
Peak current [A _{rms}]	I_{max}	5.9	10.8	3.0	5.9
Maximum speed [rpm]	n_{max}	3,800	7,240	3,500	6,900
Voltage constant at 1,000 rpm [V _{rms}]	k_e	55.6	29.6	108.4	55.1
Torque constant [Nm / A _{rms}]	k_t	0.92	0.49	1.79	0.91
Winding resistance (2 phases) at 20 °C [Ω]	R_{p-p}	9.6	2.9	33.9	9.6
Winding inductance (2 phases) [mH]	L_{p-p}	16.9	7.9	105.2	16.9
Electrical time constant [ms]	t_{el}	1.8	2.7	3.1	1.8
Thermal time constant [min]	t_{th}	25	25	25	25
Moment of inertia rotor [kg·cm ²]	J	4.50E-01	4.50E-01	4.50E-01	4.50E-01
Weight of motor [kg]	m	2.0	2.0	2.0	2.0

For standstill / rated current greater than 30 A, observe connection technology (Page 48) and encoder selection (Page 46)!
Other voltage variants available on request.

Performance

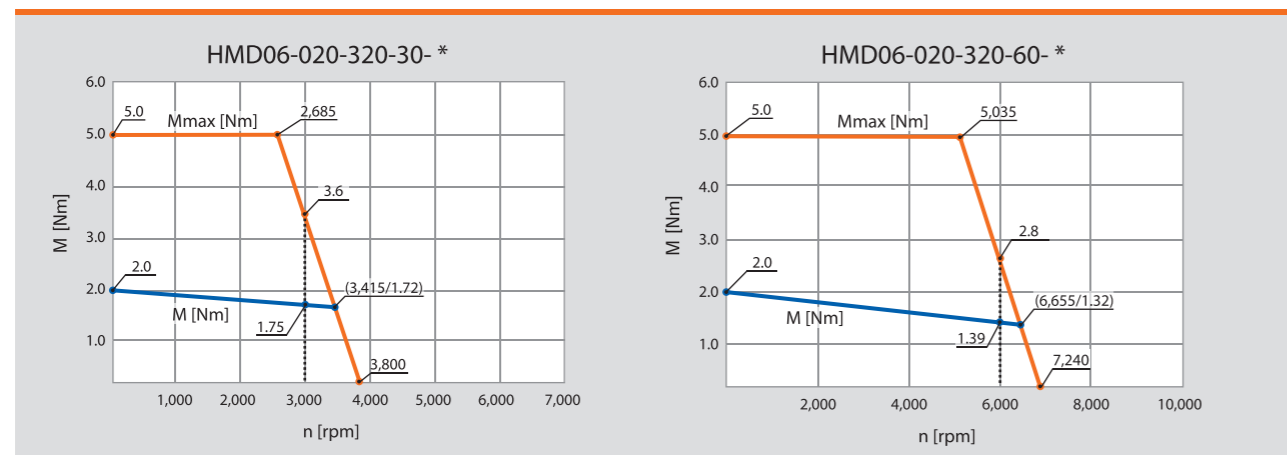

Dimensions

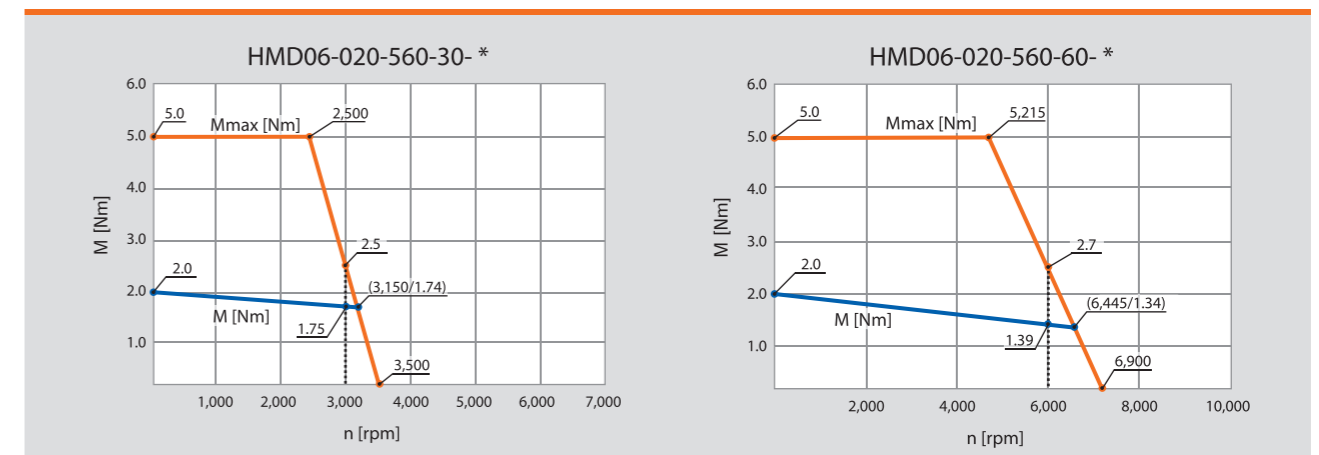
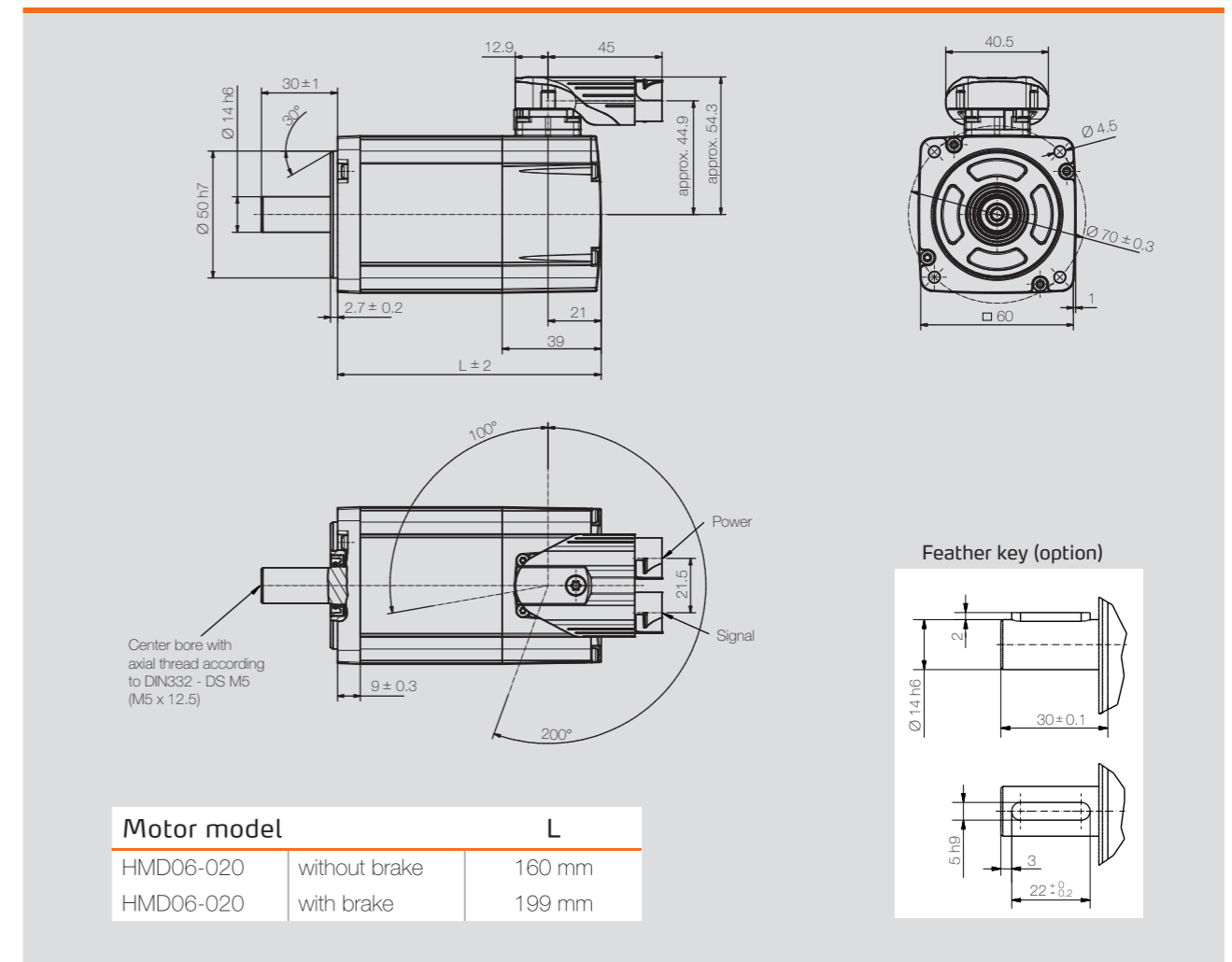

HMD08-020
24 / 48 V



Specifications

	HMD08-020				
Rated speed [rpm]	n_n	3,000	5,500	3,000	5,500
Number of pole pairs		3	3	3	3
Wiring of the motor winding		Y	Y	Y	Y
DC bus voltage [V _{DC}]	U_{bus}	24	24	48	48
Rated voltage motor [V _{ms}]	U_{mot}	12	13	25	21
Rated power [W]	P_n	500	750	500	750
Rated torque [Nm]	M_n	1.6	1.3	1.6	1.3
Rated current per phase [A _{rms}]	I_n	28.5	39.5	14.4	23.8
Stall torque [Nm]	M_0	2.0	2.0	2.0	2.0
Stall current per phase [A _{rms}]	I_0	35.4	58.5	18.0	35.4
Peak torque [Nm]	M_{max}	5.0	5.0	5.0	5.0
Peak current [A _{rms}]	I_{max}	88.5	146.3	45.0	88.5
Maximum speed [rpm]	n_{max}	4,195	6,930	4,195	8,390
Voltage constant at 1,000 rpm [V _{ms}]	k_e	3.8	2.3	7.6	3.8
Torque constant [Nm / A _{rms}]	k_t	0.06	0.04	0.13	0.06
Winding resistance (2 phases) at 20 °C [Ω]	R_{p-p}	0.04	0.02	0.17	0.04
Winding inductance (2 phases) [mH]	L_{p-p}	0.18	0.07	0.73	0.18
Electrical time constant [ms]	t_{el}	4.7	4.5	4.4	4.7
Thermal time constant [min]	t_{th}	30	30	30	30
Moment of inertia rotor [kg-cm ²]	J	6.63E-01	6.63E-01	6.63E-01	6.63E-01
Weight of motor [kg]	m	2.2	2.2	2.2	2.2

Dimensions

Technical drawings showing dimensions for the motor. Key dimensions include: shaft diameter $\varnothing 19\text{ h7}$, shaft length 35 ± 1 , motor length $L \pm 2$, and mounting hole diameter $\varnothing 5.5$. The drawings also show a 30° chamfer and a 100°/200° angle on the shaft.

Motor model	L	
HMD08-020 without brake	124 mm	
HMD08-020 with brake	172 mm	

Feather key (option)

For standstill / rated current greater than 30 A, observe connection technology (Page 48) and encoder selection (Page 46)!
Other voltage variants available on request.

Performance

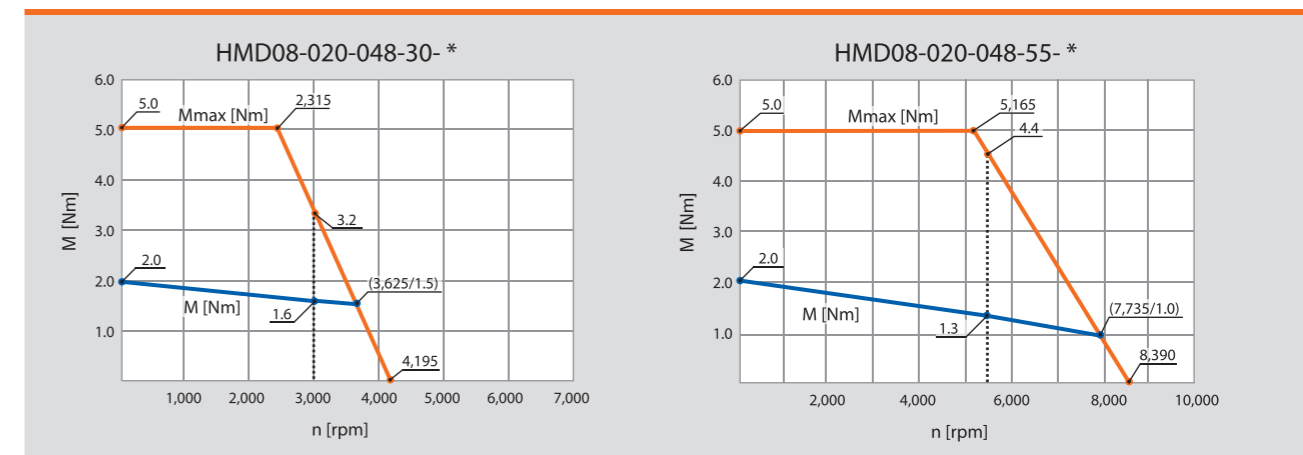
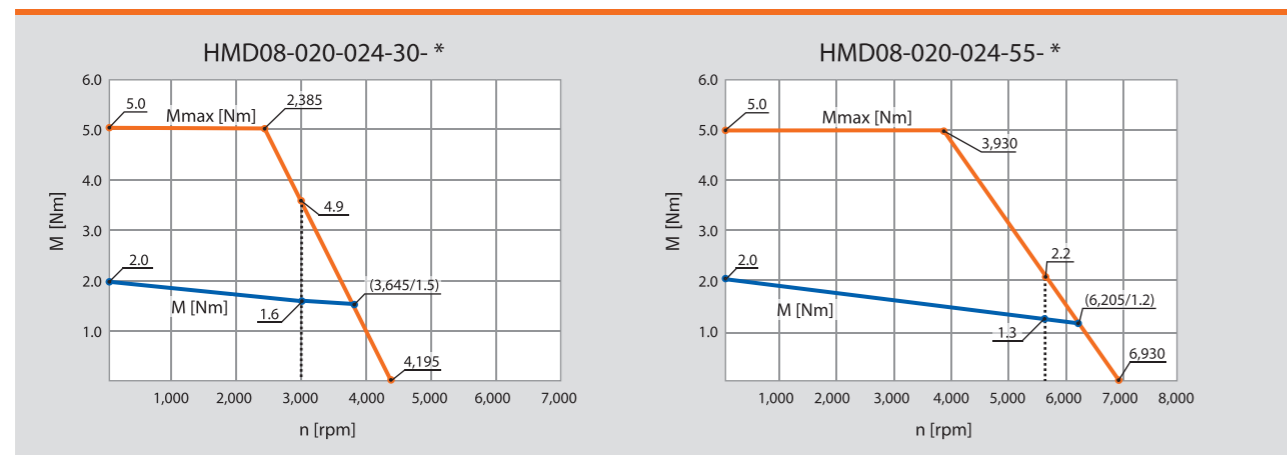

HMD08-020

320 / 560 V



Specifications

	HMD08-020				
Rated speed [rpm]	n_n	3.000	5.500	3.000	5.500
Number of pole pairs		3	3	3	3
Wiring of the motor winding		Y	Y	Y	Y
DC bus voltage [V _{DC}]	U_{bus}	320	320	560	560
Rated voltage motor [V _{rms}]	U_{mot}	173	167	322	300
Rated power [W]	P_n	500	750	500	750
Rated torque [Nm]	M_n	1.6	1.3	1.6	1.3
Rated current per phase [A _{rms}]	I_n	2.0	3.0	1.1	1.7
Stall torque [Nm]	M_0	2.0	2.0	2.0	2.0
Stall current per phase [A _{rms}]	I_0	2.5	4.5	1.4	2.5
Peak torque [Nm]	M_{max}	5.0	5.0	5.0	5.0
Peak current [A _{rms}]	I_{max}	6.3	11.3	3.4	6.3
Maximum speed [rpm]	n_{max}	3.960	7.165	3.675	6.880
Voltage constant at 1.000 rpm [V _{rms}]	k_e	53.4	29.5	99.9	53.4
Torque constant [Nm / A _{rms}]	k_t	0.88	0.49	1.65	0.88
Winding resistance (2 phases) at 20 °C [Ω]	R_{p-p}	8.10	2.30	27.10	8.10
Winding inductance (2 phases) [mH]	L_{p-p}	36.30	11.70	125.80	36.30
Electrical time constant [ms]	t_{el}	4.5	5.1	4.6	4.5
Thermal time constant [min]	t_{th}	30	30	30	30
Moment of inertia rotor [kg-cm ²]	J	6.63E-01	6.63E-01	6.63E-01	6.63E-01
Weight of motor [kg]	m	2.2	2.2	2.2	2.2

For standstill / rated current greater than 30 A, observe connection technology (Page 48) and encoder selection (Page 46)!
Other voltage variants available on request.

Performance

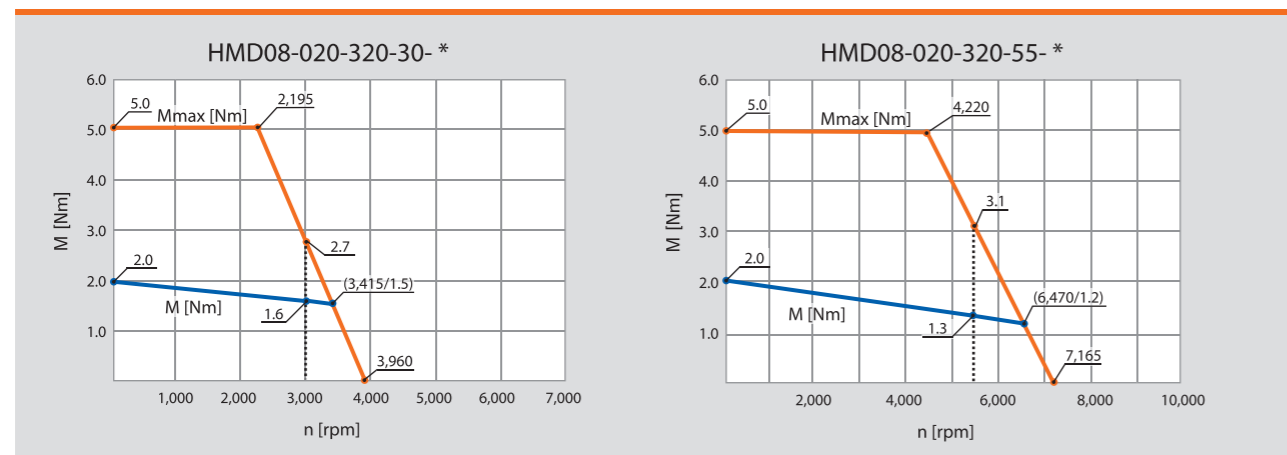

Dimensions

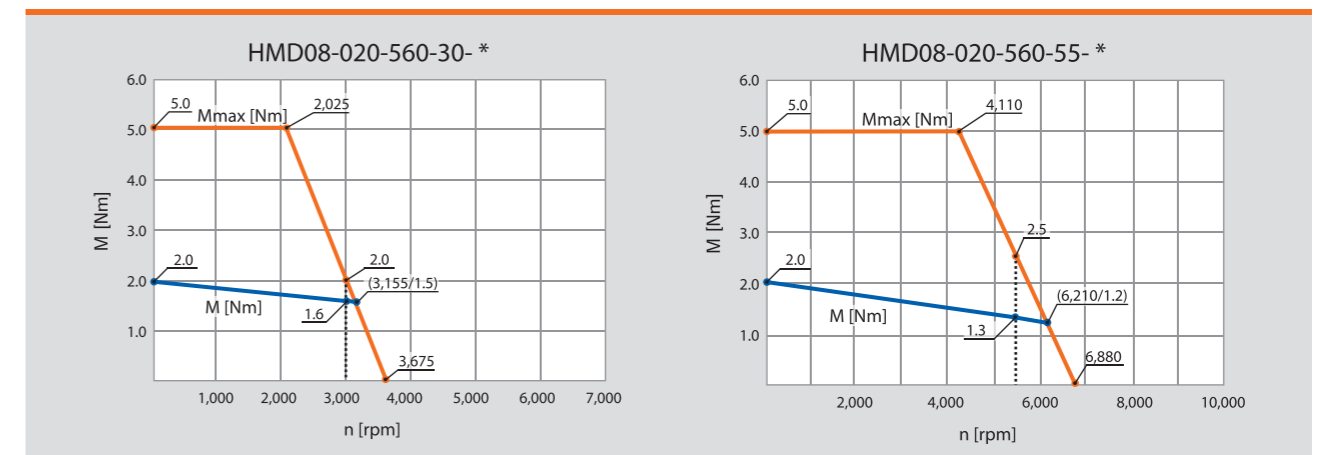
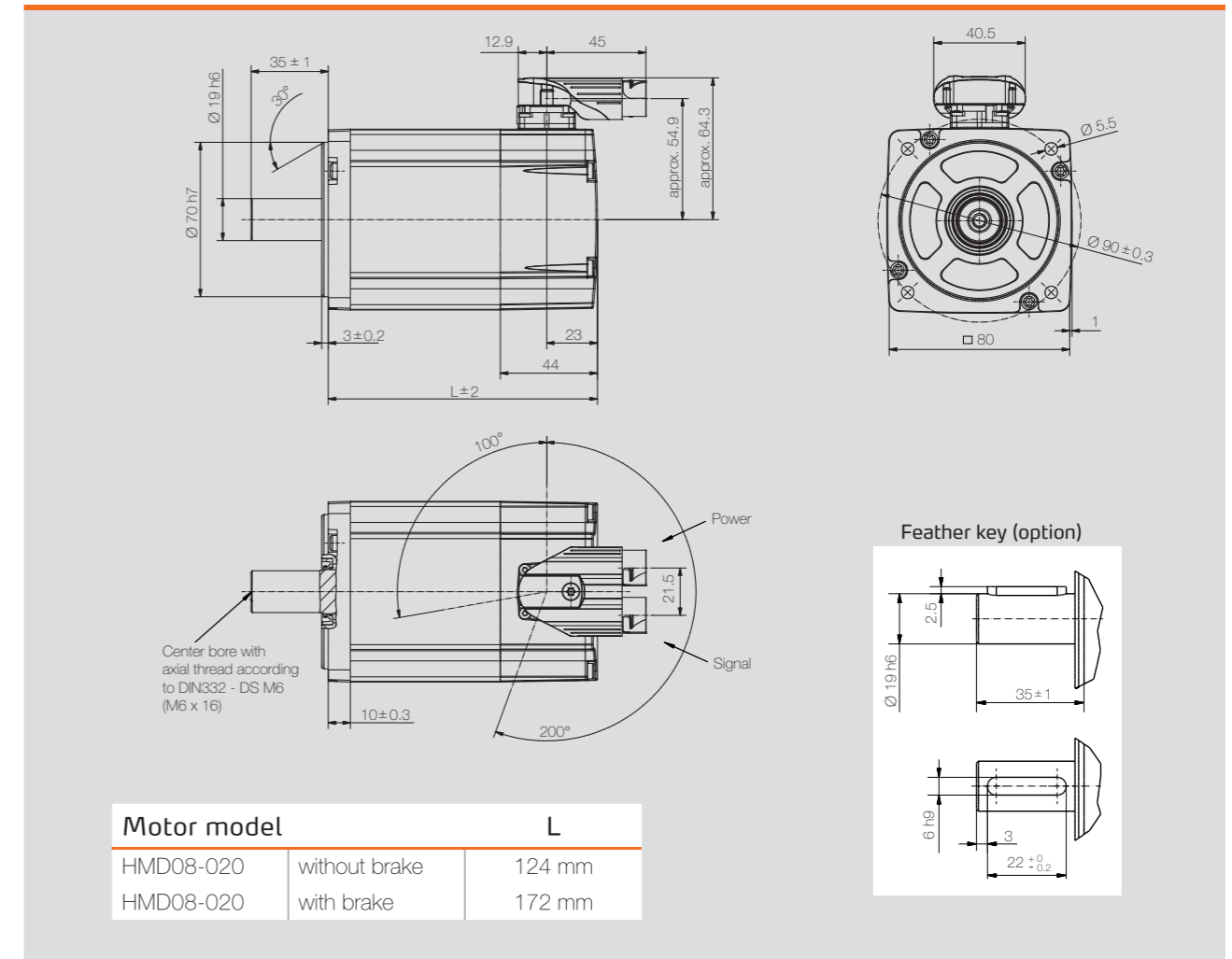

HMD08-028
24 / 48 V



Specifications

	HMD08-028				
Rated speed [rpm]	n_n	3,000	5,500	3,000	5,500
Number of pole pairs		3	3	3	3
Wiring of the motor winding		Y	Y	Y	Y
DC bus voltage [V _{DC}]	U_{bus}	24	24	48	48
Rated voltage motor [V _{ms}]	U_{mot}	13	9	23	22
Rated power [W]	P_n	750	1,000	750	1,000
Rated torque [Nm]	M_n	2.4	1.7	2.4	1.7
Rated current per phase [A _{rms}]	I_n	41.3	69.9	22.2	29.9
Stall torque [Nm]	M_0	2.8	2.8	2.8	2.8
Stall current per phase [A _{rms}]	I_0	47.7	110.6	25.5	47.7
Peak torque [Nm]	M_{max}	7.0	7.0	7.0	7.0
Peak current [A _{rms}]	I_{max}	119.3	276.5	63.8	119.3
Maximum speed [rpm]	n_{max}	3,985	9,710	4,305	7,970
Voltage constant at 1,000 rpm [V _{ms}]	k_e	4.0	1.7	7.4	4.0
Torque constant [Nm / A _{rms}]	k_t	0.07	0.03	0.12	0.07
Winding resistance (2 phases) at 20 °C [Ω]	R_{p-p}	0.02	0.01	0.08	0.02
Winding inductance (2 phases) [mH]	L_{p-p}	0.13	0.03	0.46	0.13
Electrical time constant [ms]	t_{el}	5.8	5.5	5.7	5.8
Thermal time constant [min]	t_{th}	30	30	30	30
Moment of inertia rotor [kg·cm ²]	J	9.30E-01	9.30E-01	9.30E-01	9.30E-01
Weight of motor [kg]	m	2.7	2.7	2.7	2.7

Dimensions

Technical drawings showing motor dimensions and internal components. Dimensions include: $\varnothing 19\ h6$, 35 ± 1 , 12.9 , 45 , 40.5 , $\varnothing 5.5$, $\varnothing 90 \pm 0.3$, 1 , 80 , 3 ± 0.2 , 23 , 44 , $L \pm 2$, 10 ± 0.3 , 21.5 , 100° , 200° , $6\ h9$, 3 , 22 ± 0.2 , 35 ± 1 , 2.5 .

Center bore with axial thread according to DIN332 - DS M6 (M6 x 16)

Power

Signal

Feather key (option)

Motor model	L
HMD08-028 without brake	139 mm
HMD08-028 with brake	187 mm

For standstill / rated current greater than 30 A, observe connection technology (Page 48) and encoder selection (Page 46)!
Other voltage variants available on request.

Performance

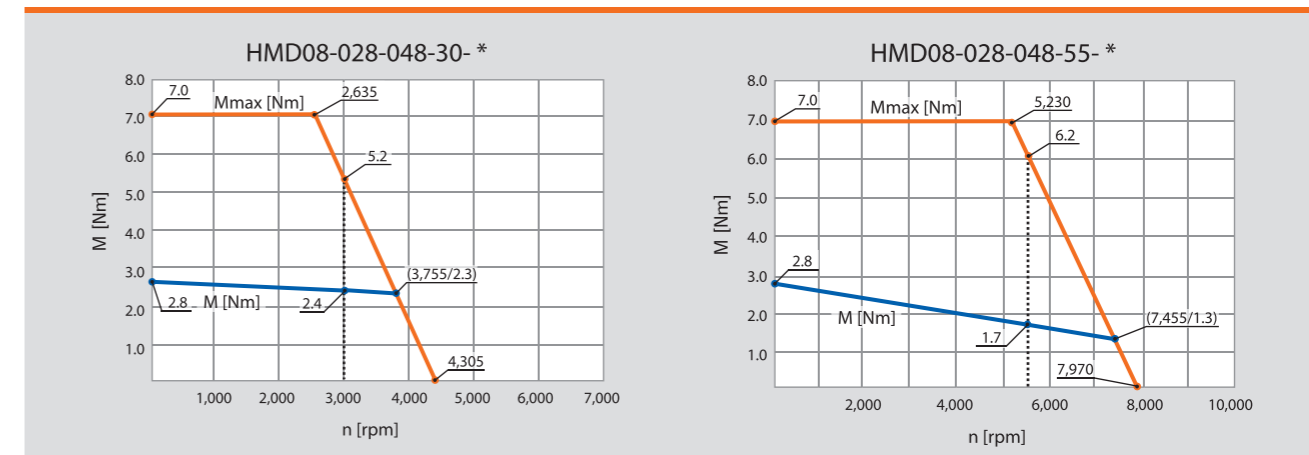
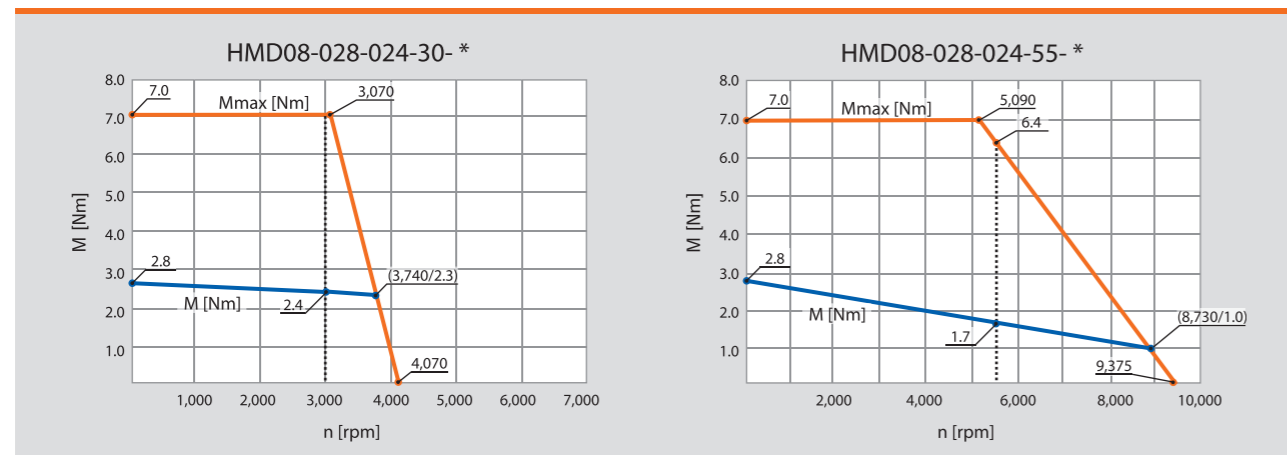

HMD08-028
320 / 560 V



Specifications

	HMD08-028				
Rated speed [rpm]	n_n	3,000	5,500	3,000	5,500
Number of pole pairs		3	3	3	3
Wiring of the motor winding		Y	Y	Y	Y
DC bus voltage [V _{DC}]	U_{bus}	320	320	560	560
Rated voltage motor [V _{rms}]	U_{mot}	179	168	319	308
Rated power [W]	P_n	750	1,000	750	1,000
Rated torque [Nm]	M_n	2.4	1.7	2.4	1.7
Rated current per phase [A _{rms}]	I_n	2.9	3.9	1.7	2.1
Stall torque [Nm]	M_0	2.8	2.8	2.8	2.8
Stall current per phase [A _{rms}]	I_0	3.4	6.2	1.9	3.4
Peak torque [Nm]	M_{max}	7.0	7.0	7.0	7.0
Peak current [A _{rms}]	I_{max}	8.4	15.4	4.6	8.4
Maximum speed [rpm]	n_{max}	3,775	7,090	3,660	6,560
Voltage constant at 1,000 rpm [V _{rms}]	k_e	56.0	29.8	100.3	56.0
Torque constant [Nm / A _{rms}]	k_t	0.93	0.49	1.66	0.93
Winding resistance (2 phases) at 20 °C [Ω]	R_{p-p}	4.7	1.4	14.8	4.7
Winding inductance (2 phases) [mH]	L_{p-p}	26.8	8.3	85.3	26.8
Electrical time constant [ms]	t_{el}	5.8	5.8	5.8	6.0
Thermal time constant [min]	t_{th}	30	30	30	30
Moment of inertia rotor [kg-cm ²]	J	9.30E-01	9.30E-01	9.30E-01	9.30E-01
Weight of motor [kg]	m	2.7	2.7	2.7	2.7

For standstill / rated current greater than 30 A, observe connection technology (Page 48) and encoder selection (Page 46)!
Other voltage variants available on request.

Performance

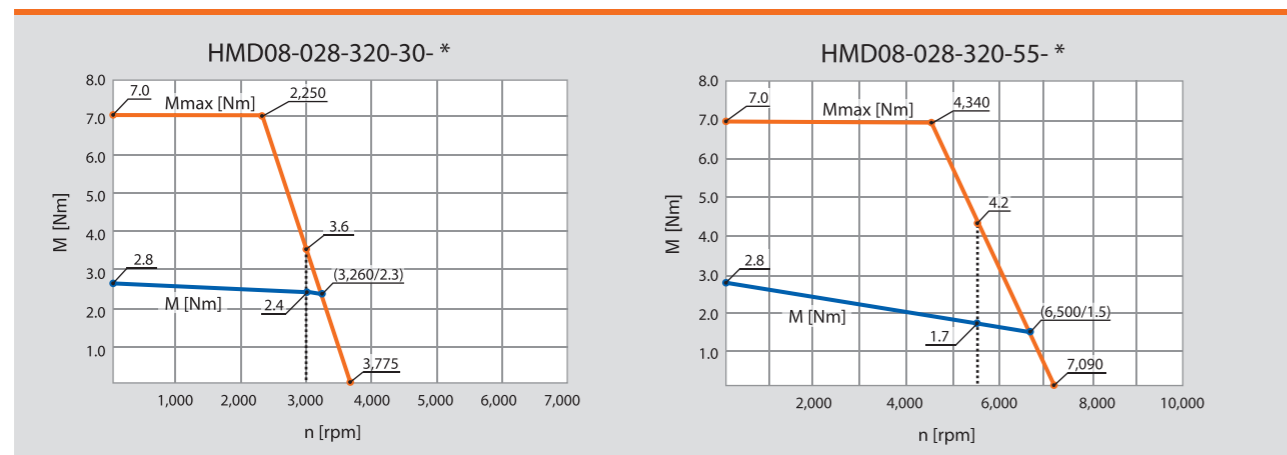

Dimensions

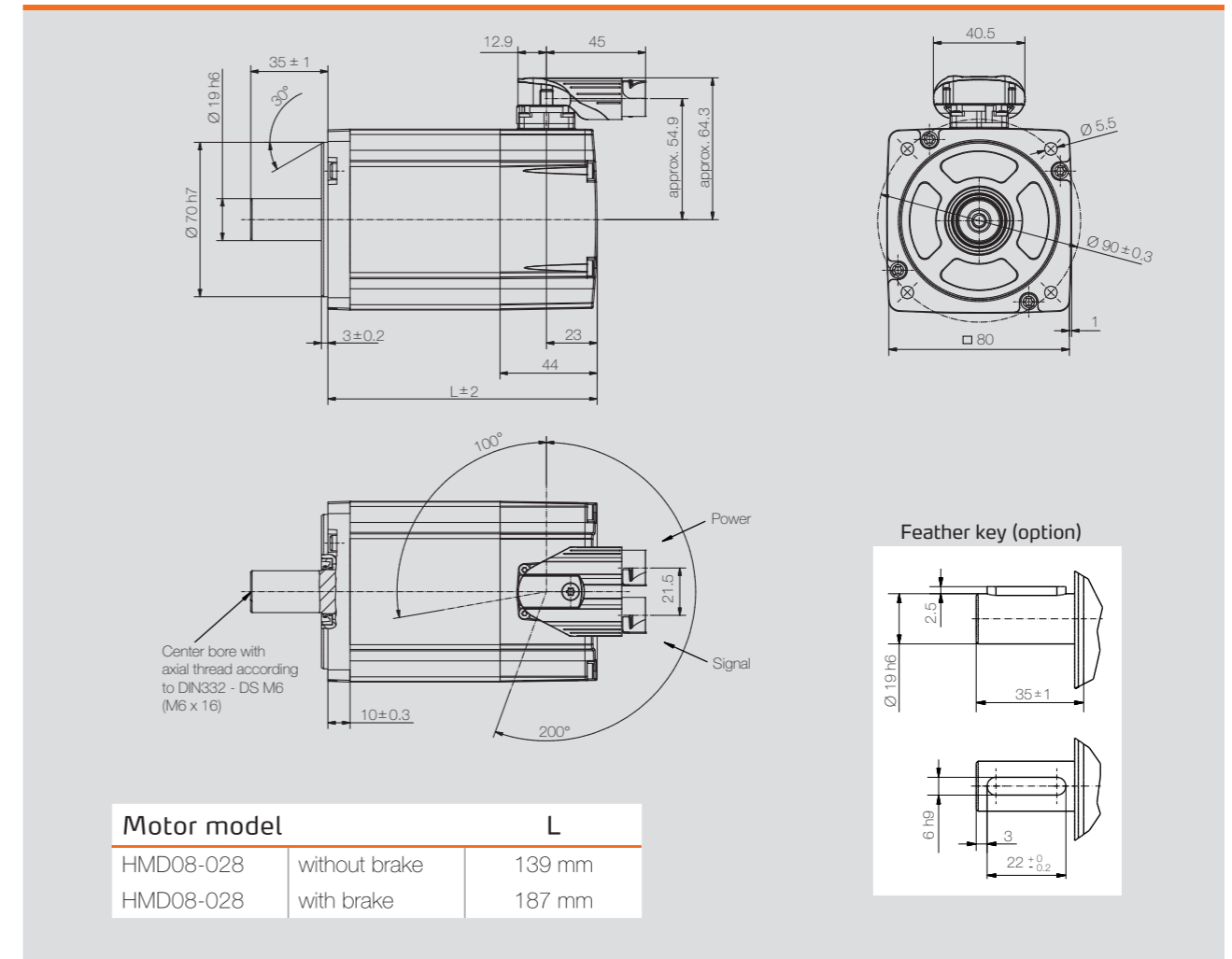

HMD08-035

24 / 48 V

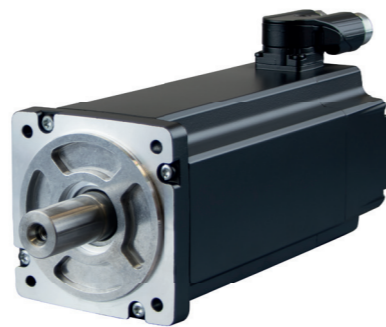

Specifications

	HMD08-035				
Rated speed [rpm]	n_n	3,000	5,500	3,000	5,500
Number of pole pairs		3	3	3	3
Wiring of the motor winding		Y	Y	Y	Y
DC bus voltage [V _{DC}]	U_{bus}	24	24	48	48
Rated voltage motor [V _{rms}]	U_{mot}	10	12	24	17
Rated power [W]	P_n	1,000	1,200	1,000	1,200
Rated torque [Nm]	M_n	3.2	2.1	3.2	2.1
Rated current per phase [A _{rms}]	I_n	72.3	64.9	28.9	48.7
Stall torque [Nm]	M_0	3.5	3.5	3.5	3.5
Stall current per phase [A _{rms}]	I_0	77.8	103.7	31.1	77.8
Peak torque [Nm]	M_{max}	8.8	8.8	8.8	8.8
Peak current [A _{rms}]	I_{max}	194.5	259.3	77.8	194.5
Maximum speed [rpm]	n_{max}	5,315	7,330	4,250	10,750
Voltage constant at 1,000 rpm [V _{rms}]	k_e	3.0	2.2	7.5	3.0
Torque constant [Nm / A _{rms}]	k_t	0.05	0.04	0.12	0.05
Winding resistance (2 phases) at 20 °C [Ω]	R_{p-p}	0.01	0.01	0.06	0.01
Winding inductance (2 phases) [mH]	L_{p-p}	0.06	0.04	0.36	0.06
Electrical time constant [ms]	t_{el}	5.8	5.8	5.9	5.8
Thermal time constant [min]	t_{th}	30	30	30	30
Moment of inertia rotor [kg-cm ²]	J	1.20E00	1.20E00	1.20E00	1.20E00
Weight of motor [kg]	m	3.2	3.2	3.2	3.2

For standstill / rated current greater than 30 A, observe connection technology (Page 48) and encoder selection (Page 46)!
Other voltage variants available on request.

Performance

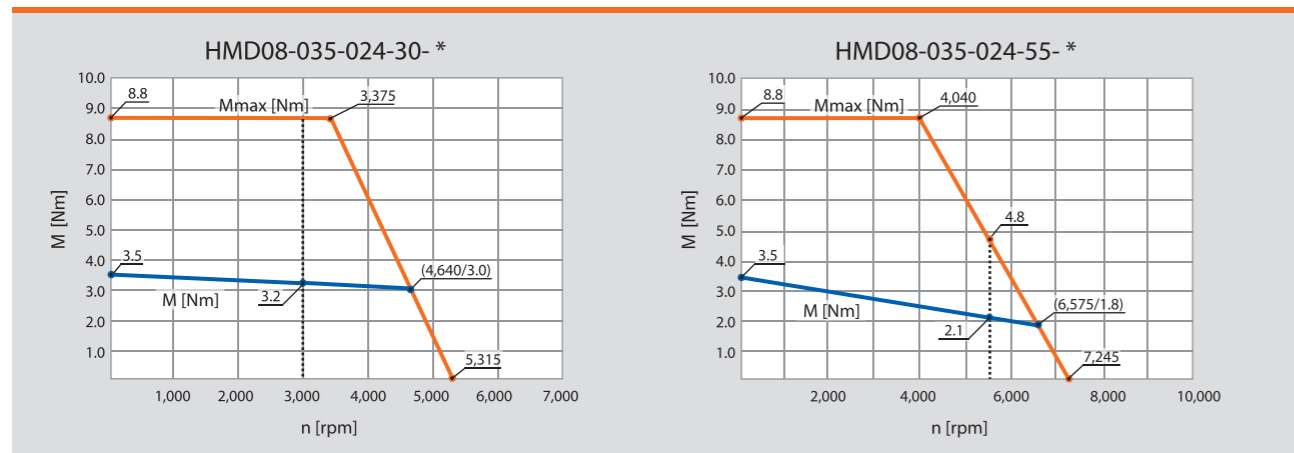

Dimensions

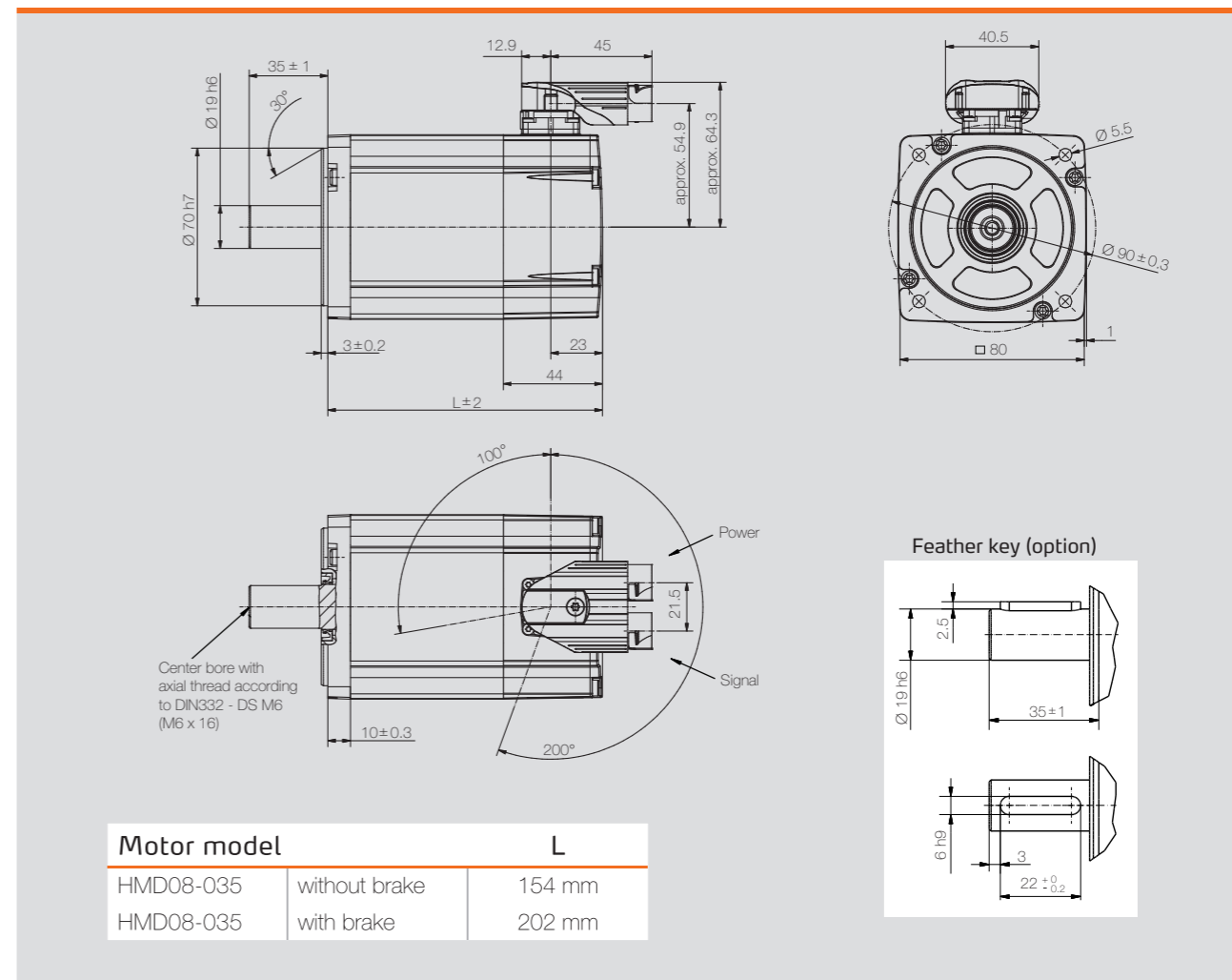

HMD08-035

320 / 560 V

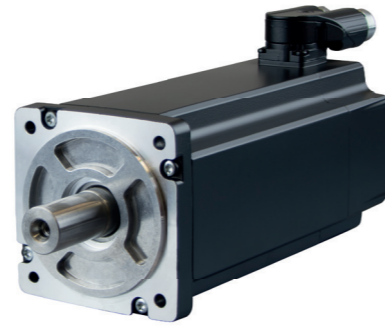

Specifications

	HMD08-035				
Rated speed [rpm]	n_n	3,000	5,500	3,000	5,500
Number of pole pairs		3	3	3	3
Wiring of the motor winding		Y	Y	Y	Y
DC bus voltage [V _{DC}]	U_{bus}	320	320	560	560
Rated voltage motor [V _{rms}]	U_{mot}	177	165	318	304
Rated power [W]	P_n	1,000	1,200	1,000	1,200
Rated torque [Nm]	M_n	3.2	2.1	3.2	2.1
Rated current per phase [A _{rms}]	I_n	3.9	4.9	2.2	2.6
Stall torque [Nm]	M_0	3.5	3.5	3.5	3.5
Stall current per phase [A _{rms}]	I_0	4.2	7.8	2.3	4.2
Peak torque [Nm]	M_{max}	8.8	8.8	8.8	8.8
Peak current [A _{rms}]	I_{max}	10.5	19.4	5.8	9.7
Maximum speed [rpm]	n_{max}	3,790	7,215	3,635	6,580
Voltage constant at 1,000 rpm [V _{rms}]	k_e	55.8	29.3	101.0	54.2
Torque constant [Nm / A _{rms}]	k_t	0.92	0.49	1.67	0.92
Winding resistance (2 phases) at 20 °C [Ω]	R_{p-p}	3.4	1.0	10.0	3.4
Winding inductance (2 phases) [mH]	L_{p-p}	19.9	3.1	65.2	21.0
Electrical time constant [ms]	t_{el}	5.8	6.0	6.5	6.1
Thermal time constant [min]	t_{th}	30	30	30	30
Moment of inertia rotor [kg-cm ²]	J	1.20E00	1.20E00	1.20E00	1.20E00
Weight of motor [kg]	m	3.2	3.2	3.2	3.2

For standstill / rated current greater than 30 A, observe connection technology (Page 48) and encoder selection (Page 46)!
Other voltage variants available on request.

Performance

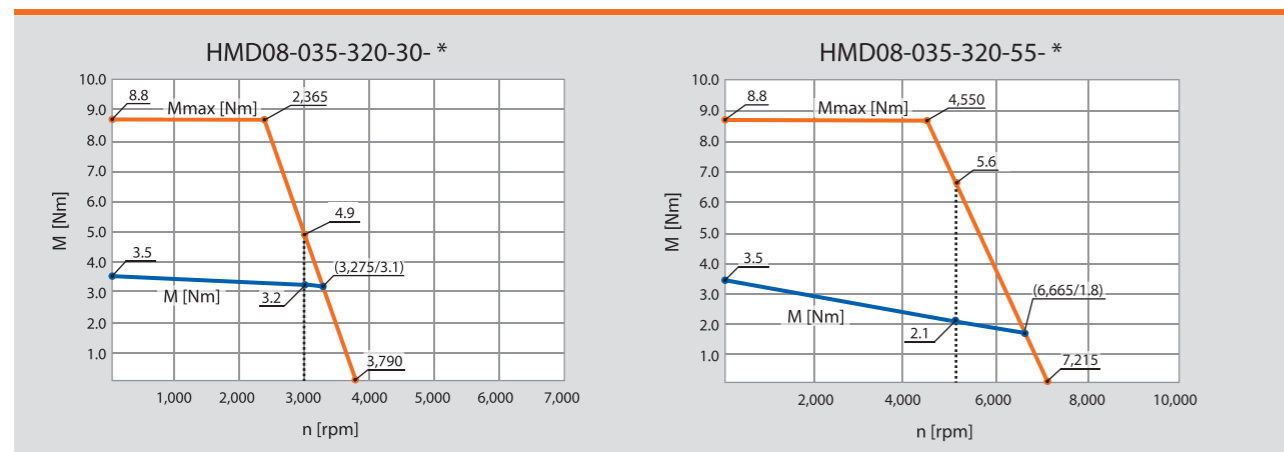

Dimensions

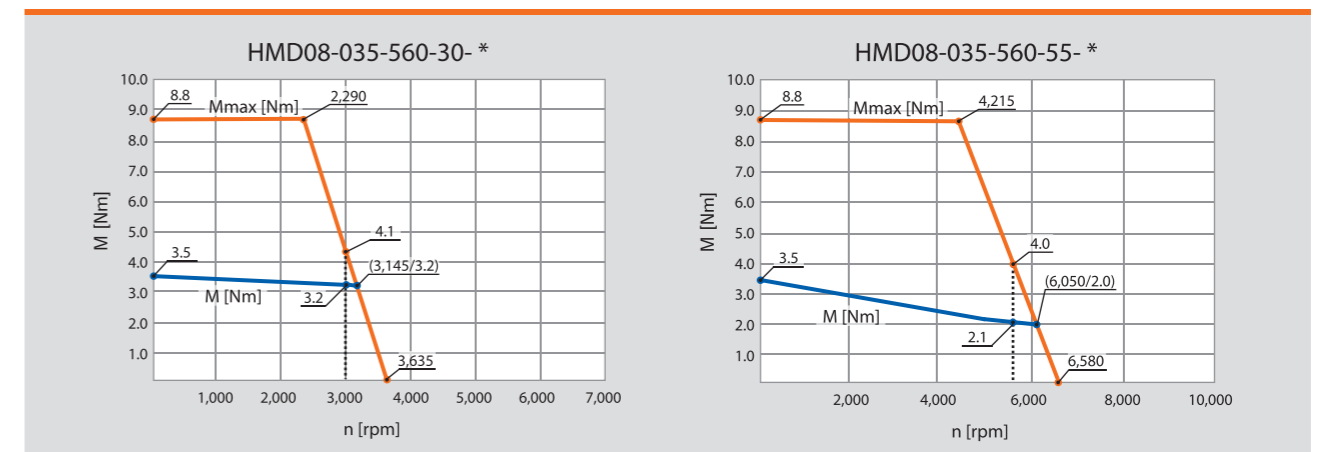
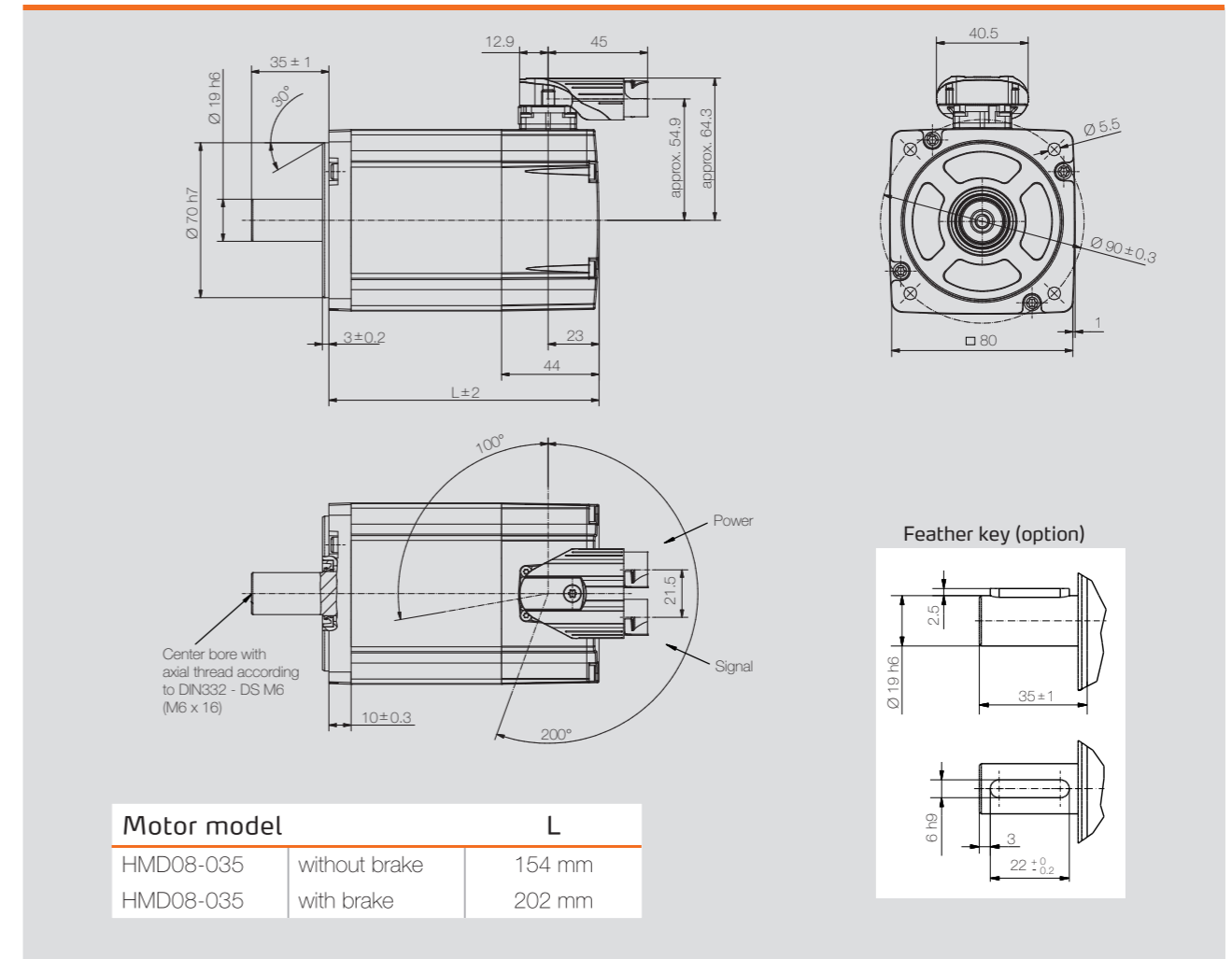

HMD08-050

24 / 48 V

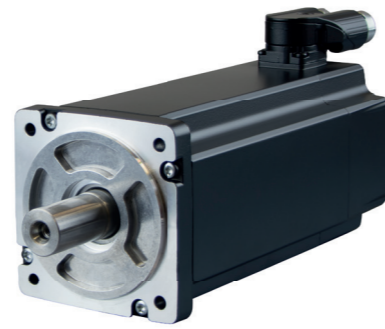

Specifications

	HMD08-050			
Rated speed [rpm]	n_n	3,000	3,000	5,500
Number of pole pairs		3	3	3
Wiring of the motor winding		Y	Y	Y
DC bus voltage [V _{DC}]	U_{bus}	24	48	48
Rated voltage motor [V _{rms}]	U_{mot}	11	22	18
Rated power [W]	P_n	1,500	1,500	1,650
Rated torque [Nm]	M_n	4.8	4.8	2.9
Rated current per phase [A _{rms}]	I_n	96.5	48.3	60
Stall torque [Nm]	M_0	5.0	5.0	5.0
Stall current per phase [A _{rms}]	I_0	98.7	49.4	98.7
Peak torque [Nm]	M_{max}	12.5	12.5	12.5
Peak current [A _{rms}]	I_{max}	246.8	123.5	246.8
Maximum speed [rpm]	n_{max}	4,690	4,690	9,480
Voltage constant at 1,000 rpm [V _{rms}]	k_e	3.4	6.8	3.4
Torque constant [Nm / A _{rms}]	k_t	0.06	0.11	0.06
Winding resistance (2 phases) at 20 °C [Ω]	R_{p-p}	0.01	0.03	0.01
Winding inductance (2 phases) [mH]	L_{p-p}	0.05	0.20	0.05
Electrical time constant [ms]	t_{el}	5.6	5.9	5.6
Thermal time constant [min]	t_{th}	30	30	30
Moment of inertia rotor [kg-cm ²]	J	1.73E00	1.73E00	1.73E00
Weight of motor [kg]	m	4.1	4.1	4.1

For standstill / rated current greater than 30 A, observe connection technology (Page 48) and encoder selection (Page 46)!
Other voltage variants available on request.

Dimensions

Technical drawings showing dimensions for the motor. Key dimensions include: shaft diameter $\varnothing 19\ h7$, shaft length 35 ± 1 , motor length $L \pm 2$, and mounting flange diameter $\varnothing 80$. A table below lists motor models and their lengths.

Motor model	L
HMD08-050 without brake	184 mm
HMD08-050 with brake	232 mm

Feather key (option) dimensions: $\varnothing 19\ h6$, length 35 ± 1 , and key width $6\ h9$.

Performance

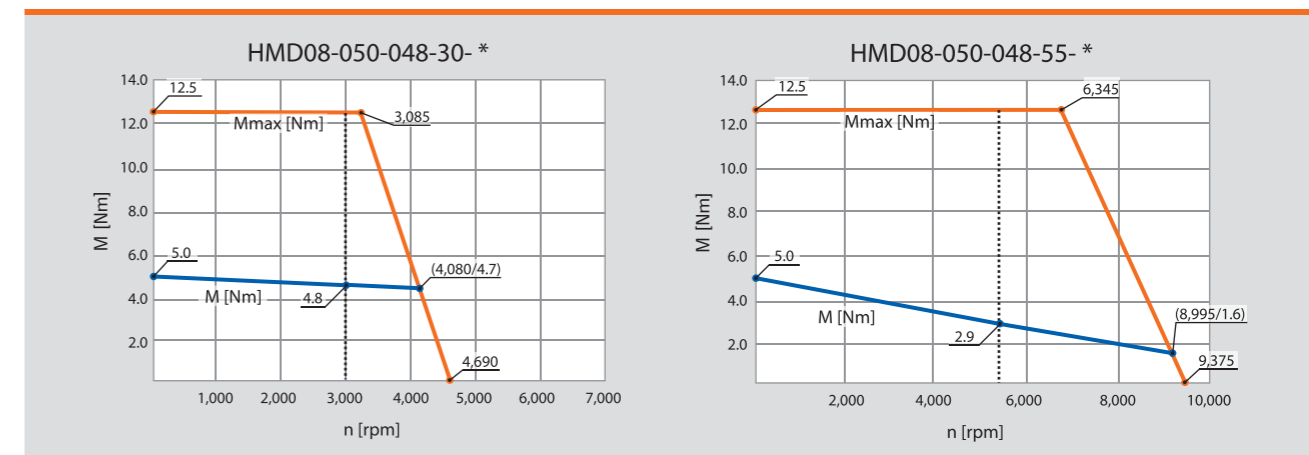
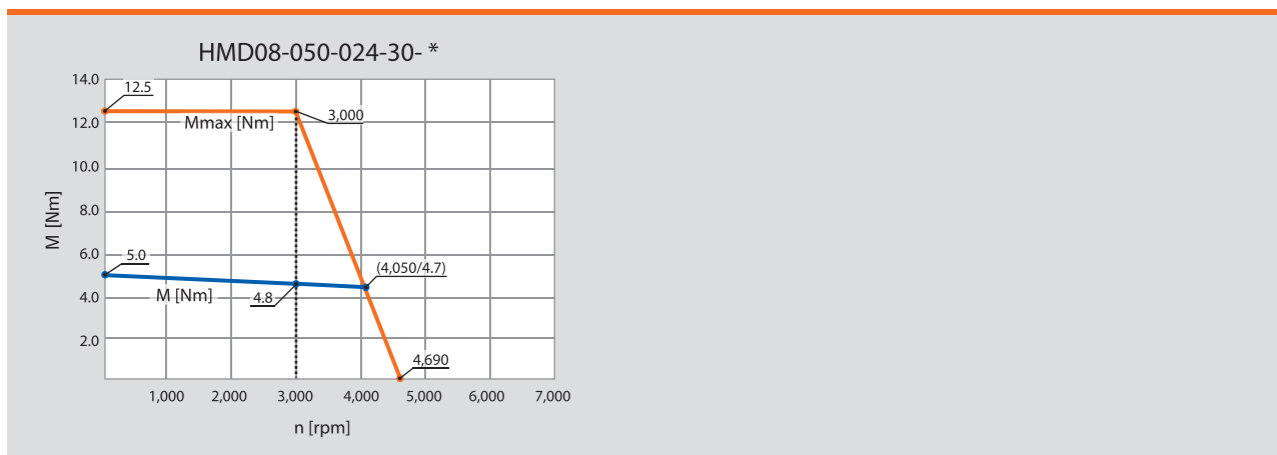

HMD08-050

320 / 560 V

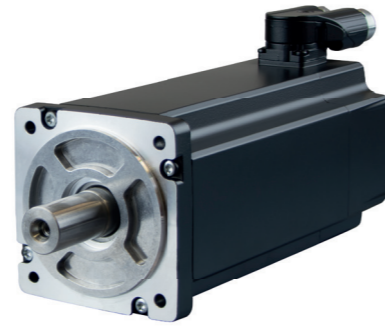

Specifications

	HMD08-050				
Rated speed [rpm]	n_n	3,000	5,500	3,000	5,500
Number of pole pairs		3	3	3	3
Wiring of the motor winding		Y	Y	Y	Y
DC bus voltage [V _{DC}]	U_{bus}	320	320	560	560
Rated voltage motor [V _{ms}]	U_{mot}	171	165	318	293
Rated power [W]	P_n	1,500	1,650	1,500	1,650
Rated torque [Nm]	M_n	4.8	2.9	4.8	2.9
Rated current per phase [A _{rms}]	I_n	6.1	6.7	3.3	3.8
Stall torque [Nm]	M_0	5.0	5.0	5.0	5.0
Stall current per phase [A _{rms}]	I_0	6.2	11.0	3.3	6.2
Peak torque [Nm]	M_{max}	12.5	12.5	12.5	12.5
Peak current [A _{rms}]	I_{max}	15.5	27.5	8.3	15.5
Maximum speed [rpm]	n_{max}	4,130	7,165	3,655	7,175
Voltage constant at 1,000 rpm [V _{ms}]	k_e	51.2	29.5	100.5	51.2
Torque constant [Nm / A _{rms}]	k_t	0.85	0.49	1.66	0.85
Winding resistance (2 phases) at 20 °C [Ω]	R_{p-p}	1.9	0.7	7.1	1.9
Winding inductance (2 phases) [mH]	L_{p-p}	12.5	4.22	43.0	12.5
Electrical time constant [ms]	t_{el}	6.5	6.1	6.0	6.5
Thermal time constant [min]	t_{th}	30	30	30	30
Moment of inertia rotor [kg·cm ²]	J	1.73E00	1.73E00	1.73E00	1.73E00
Weight of motor [kg]	m	4.1	4.1	4.1	4.1

Dimensions

Technical drawings showing dimensions for the motor. Key dimensions include: 35 ± 1, 12.9, 45, 19 h6, 30°, 70 h7, 3 ± 0.2, 23, 44, L ± 2, 40.5, 5.5, 90 ± 0.3, 1, 100°, 200°, 21.5, 10 ± 0.3, 2.5, 35 ± 1, 6 h9, 3, 22 ± 0.2.

Center bore with axial thread according to DIN332 - DS M6 (M6 x 16)

Power

Signal

Feather key (option)

Motor model	L
HMD08-050 without brake	184 mm
HMD08-050 with brake	232 mm

For standstill / rated current greater than 30 A, observe connection technology (Page 48) and encoder selection (Page 46)!
Other voltage variants available on request.

Performance

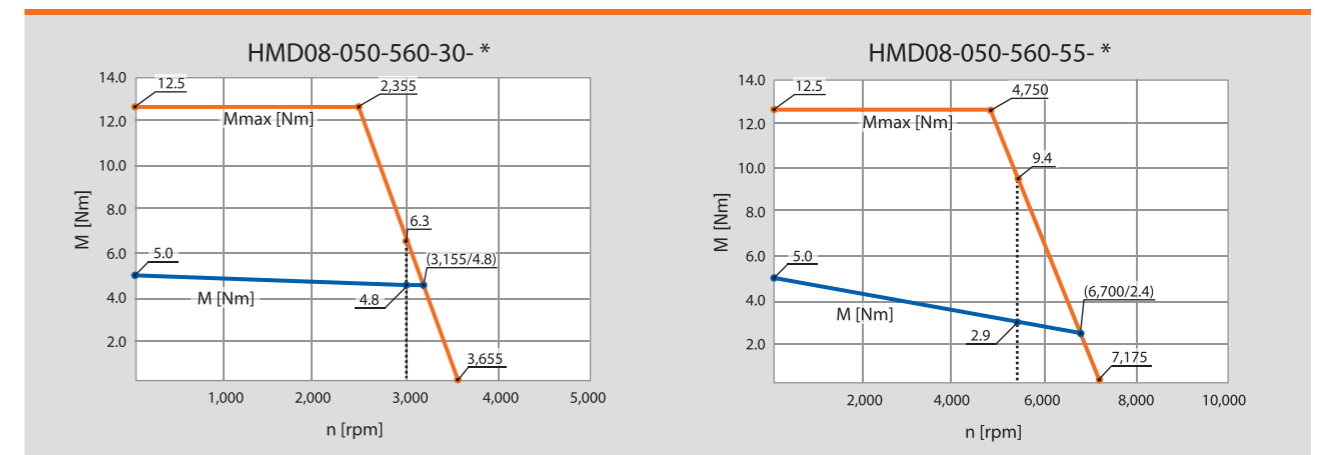
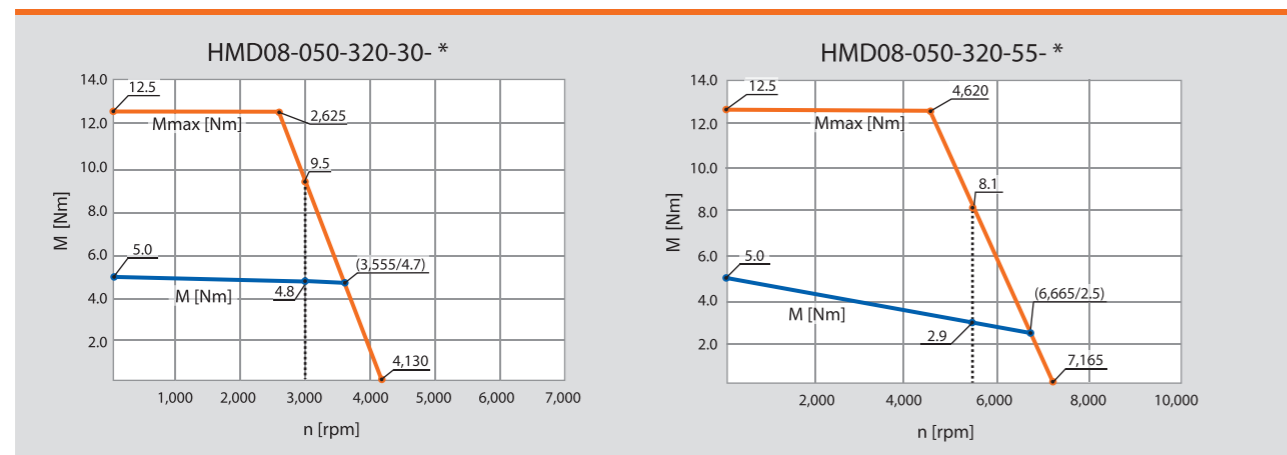

Configuration options

Feedback options

As standard, HeiMotion Dynamic motors are supplied with a resolver. As an option, various encoders with different interfaces can be mounted to the series.

Motor model	Resolver *	CKS36	ECI 1118	EQI 1131
	standard	incremental resolver	EnDat 2.2	EnDat 2.2
HMD06-XXX-024-*	X		X	
HMD06-XXX-048-*	X		X	
HMD06-XXX-320-*	X	X	X	X
HMD06-XXX-560-*	X	X	X	X
HMD08-XXX-024-*	X		X	
HMD08-XXX-048-*	X		X	
HMD08-XXX-320-*	X	X	X	X
HMD08-XXX-560-*	X	X	X	X
	p. 50	p. 51	p. 52	

Motor model	SEK/ SEL37	SKS/ SKM36 *	SRS/ SRM50	EES/ EEM37	EKS/ EKM36 *	EFS/ EFM50	HES/ HEM
	HIPERFACE®	HIPERFACE®	HIPERFACE®	HIPERFACE DSL®	HIPERFACE DSL®	HIPERFACE DSL®	hall encoder
HMD06-XXX-024-*	X						X
HMD06-XXX-048-*	X						X
HMD06-XXX-320-*	X	X		X	X		X
HMD06-XXX-560-*	X	X		X	X		X
HMD08-XXX-024-*	X						X
HMD08-XXX-048-*	X						X
HMD08-XXX-320-*	X	X	X	X	X	X	X
HMD08-XXX-560-*	X	X	X	X	X	X	X
		p. 54		p. 56			p. 58

* Safety enhanced version available to allow use of motors in applications up to cat. 3/PL d. acc. to EN ISO 13849-1 and SIL2 acc. to EN 62061/EN 61800-5-2

Alternative encoder systems upon request

Connection options

The different variants of the connection options can be found on the following pages (p. 48 and p. 49).

Effective current motor

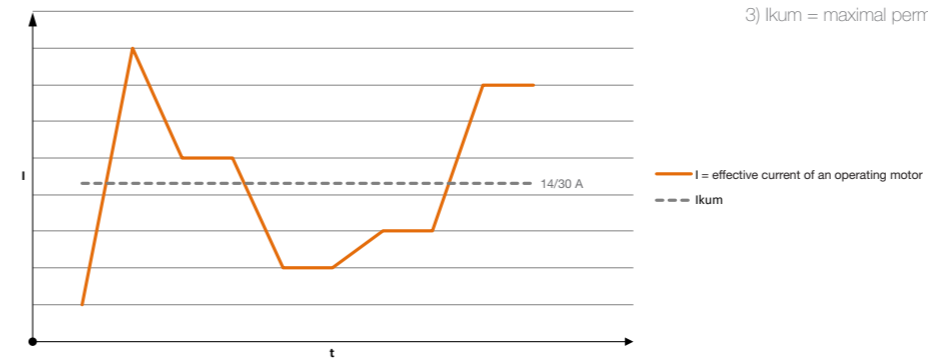

Servo drive and feedback device compatibility

Feedback device type	HCD	HCE	HCF	HCJ
Resolver		X	X	X
HIPERFACE® encoder		X		X
HIPERFACE DSL® encoder				X
Incremental encoder		X	X	X
Hall encoder (HES/HEM)	X	X	X	X
EnDat encoder				X
	p. 68	p. 70	p. 72	p. 74

■ Connection technology

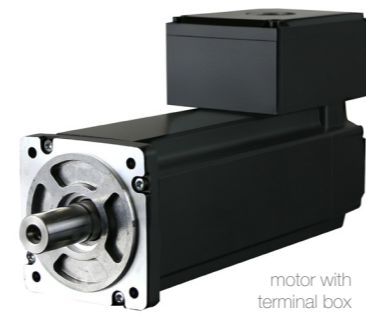

motor with terminal box

Connection technology

Motor model	Y-Tec ¹⁾	2 x M23 ¹⁾	I-Tec ¹⁾	1 x M23 ¹⁾	terminal box
HMD06-005-024-30	X	X		X	
HMD06-005-024-60		X		X	
HMD06-005-048-30	X	X	X	X	
HMD06-005-048-60	X	X	X	X	
HMD06-005-320-30	X	X	X	X	
HMD06-005-320-60	X	X	X	X	
HMD06-005-560-30	X	X	X	X	
HMD06-005-560-60	X	X	X	X	
HMD06-010-024-30		X		X	
HMD06-010-024-60		X		X	
HMD06-010-048-30	X	X	X	X	
HMD06-010-048-60		X		X	
HMD06-010-320-30	X	X	X	X	
HMD06-010-320-60	X	X	X	X	
HMD06-010-560-30	X	X	X	X	
HMD06-010-560-60	X	X	X	X	
HMD06-015-024-30		X		X	
HMD06-015-024-60		X		X	
HMD06-015-048-30	X	X	X	X	
HMD06-015-048-60		X		X	
HMD06-015-320-30	X	X	X	X	
HMD06-015-320-60	X	X	X	X	
HMD06-015-560-30	X	X	X	X	
HMD06-015-560-60	X	X	X	X	
HMD06-020-024-30		X		X	
HMD06-020-024-60					
HMD06-020-048-30		X		X	
HMD06-020-048-60		X		X	
HMD06-020-320-30	X	X	X	X	
HMD06-020-320-60	X	X	X	X	
HMD06-020-560-30	X	X	X	X	
HMD06-020-560-60	X	X	X	X	
HMD08-020-024-30		X		X	X
HMD08-020-024-55					X
HMD08-020-048-30		X		X	X
HMD08-020-048-55		X		X	X

Motor model	Y-Tec ¹⁾	2 x M23 ¹⁾	I-Tec ¹⁾	1 x M23 ¹⁾	terminal box
HMD08-020-320-30	X	X	X	X	
HMD08-020-320-55	X	X	X	X	
HMD08-020-560-30	X	X	X	X	
HMD08-020-560-55	X	X	X	X	
HMD08-028-024-30					X
HMD08-028-024-55					X
HMD08-028-048-30		X		X	X
HMD08-028-048-55					X
HMD08-028-320-30	X	X	X	X	
HMD08-028-320-55	X	X	X	X	
HMD08-028-560-30	X	X	X	X	
HMD08-028-560-55	X	X	X	X	
HMD08-035-024-30					X
HMD08-035-024-55					X
HMD08-035-048-30		X		X	X
HMD08-035-048-55					X
HMD08-035-320-30	X	X	X	X	
HMD08-035-320-55	X	X	X	X	
HMD08-035-560-30	X	X	X	X	
HMD08-035-560-55	X	X	X	X	
HMD08-050-024-30					X
HMD08-050-048-30					X
HMD08-050-048-55					X
HMD08-050-320-30	X	X	X	X	
HMD08-050-320-55	X	X	X	X	
HMD08-050-560-30	X	X	X	X	
HMD08-050-560-55	X	X	X	X	
HMD08-060-320-30	X	X	X	X	X
HMD08-060-320-55	X	X	X	X	X
HMD08-060-560-30	X	X	X	X	X
HMD08-060-560-55	X	X	X	X	X
Rated current connection [Arms]	15.0	30.0	15.0	30.0	50.0
max. cross-sectional area [mm ²]	2.5	4.0	2.5	4.0	10.0
	p. 62	p. 64	p. 66	p. 67	

Standard Resolver

Specifications	RE-15
Number of pole pairs	1
Input frequency	10 kHz
Input voltage	7 V _{rms}
Maximum current input	50 mA
Transformation ratio	0.5 ± 10 %
Phase shift (nominal)	3 ± 3°
Ohmic resistance (at 25 °C)	
Stator winding	70 ± 10 %
Rotor winding	24 ± 10 %
Impedances	
Z _{ro} (no-load impedance rotor)	typ. 86 j 120
Z _{rs} (short-circuit impedance rotor)	typ. 70 j 105
Z _{so} (no-load impedance stator)	typ. 140 j 273
Z _{ss} (short-circuit impedance stator)	typ. 122 j 244
Maximum residual voltage	30 mV
Maximum electrical error	± 10'
Weight	77 g
Protection class	IP20
Insulation class	F
Insulation test housing / winding	500 V _{AC} / 50 Hz / 1 s
Moment of inertia rotor	15 g·cm ²



Environmental

Working environment	IE 32 according to EN 60721-3-3
Operating temperature	- 55 °C to 155 °C
Vibration according to EN 60068-2-6	100 m/s ² 10 - 150 Hz
Impact strength	400 m/s ² 6 ms
Maximum operating speed	20,000 rpm

Dimensions

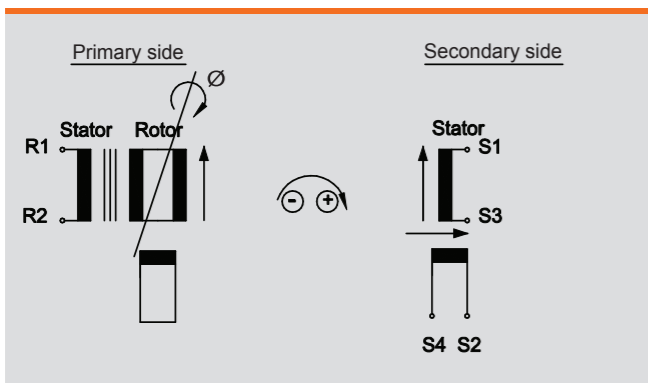

Safety norms

Safety Integrity Level	SIL 2 (EN 61800-5-2 / EN 62061)
Category	3 (EN ISO 13849-1)
Performance Level	PLd (EN ISO 13849-1)



Option Incremental encoder

Optical sensing encoder

CKS36 (Incremental encoder)



Specifications:

- Resolution 2,048 pulses per revolution
- Commutation signals for 3 pole pairs
- Index pulse 90°

Specifications according to DIN 32878

CKS36

Number of lines per revolution		2,048
Commutation signals		3 pole pairs
Measurement step		90° / number of lines
Reference signal	Number Position	1 90° electrical, logically linked with A and B
Error limits	„binary“ number of lines „non-binary“ number of lines	± 0.09° ± 0.13°
Measurement step deviation	„binary“ number of lines „non-binary“ number of lines	± 0.035° ± 0.07°
Maximum output frequency	TTL/RS 422	400 kHz
Resistance	to shocks to vibration	100 g (6 ms) 50 g (10 ... 2,000 Hz)
Operating voltage range		5 V ± 10 %
Maximum operating current without load		60 mA
Interface signals	Incremental and commutation signals Parameterization interface	according to EIA 422 IIC-Bus

Option absolute encoders

Inductive sensing encoder EnDat 2.2

ECl118

(Single-turn encoder)

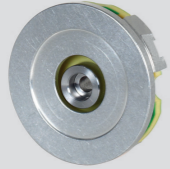

Specifications:

- Inductive rotary encoder without integral bearing
- Purely serial EnDat 2.2 interface
- For machines with high demanding dynamics and robustness
- High system accuracy
- Digital data transfer
- Electronic type label

EnDat 2.2

EQI1131

(Multi-turn encoder)



Specifications:

- Inductive rotary encoder without integral bearing
- Multi-turn via gearbox
- Purely serial EnDat 2.2 interface
- For machines with high demanding dynamics and robustness
- High system accuracy
- Digital data transfer
- Electronic type label

EnDat 2.2

Specifications

	ECl118	EQI1131
Encoder type	inductive	inductive
Position values / revolution	262,144 18 bit	524,288 19 bit
Revolutions	-	4,096 12 bit
Calculation time t_{cal}	$\leq 6 \mu s$	$\leq 5 \mu s$
Clock frequency	$\leq 8 \text{ MHz}$	$\leq 16 \text{ MHz}$
System accuracy	$\pm 120''$	$\pm 120''$
Maximum operating temperature	+ 115 °C - 20 °C	+ 110 °C - 40 °C
Mechanically permissible speed	15,000 rpm	12,000 rpm
Voltage supply	3.6 - 14 V _{DC}	3.6 - 14 V _{DC}
Max. power consumption	520 - 600 mW	700 - 850 mW
Current consumption (typical) at 5 V	80 mA	115 mA
Multiturn	-	gearbox
Vibration 55 Hz to 2,000 Hz	$\leq 300 \text{ m/s}^2$	$\leq 400 \text{ m/s}^2$
Shock 6 ms	$\leq 1,000 \text{ m/s}^2$	$\leq 2,000 \text{ m/s}^2$
Digital interface	EnDat 2.2	EnDat 2.2

Option absolute encoders

Capacitive sensing encoder - HIPERFACE®

SEK / SEL37

(Single- or multi-turn encoder)



Specifications:

- 16 sin/cos periods per revolution
- Absolute position with a resolution of 512 steps per revolution
- Measuring of 4,096 revolutions (multi-turn)
- Programming of the position value
- HIPERFACE®-interface
- Electronic type label



Optical sensing encoder - HIPERFACE®

SKS / SKM36

(Single- or multi-turn encoder)

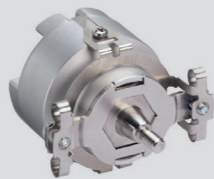

Specifications:

- 128 sin/cos periods per revolution
- Absolute position with a resolution of 4,096 steps per revolution
- Measuring of 4,096 revolutions (multi-turn)
- Programming of the position value
- HIPERFACE®-interface
- Electronic type label



SRS / SRM50

(Single- or multi-turn encoder)

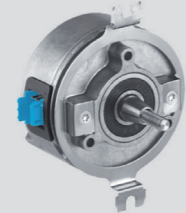

Specifications:

- 1,024 sin/cos periods per revolution
- Absolute position with a resolution of 32,768 steps per revolution
- Measuring of 4,096 revolutions (multi-turn)
- Programming of the position value
- HIPERFACE®-interface
- Electronic type label



Specifications

	SEK/SEL37	SKS/SKM36	SRS/SRM50
Number of sin/cos periods per revolution	16	128	1,024
Maximum number of turns	Single SEK 1 Multi SEL 4,096	Single SKS 1 Multi SKM 4,096	Single SRS 1 Multi SRM 4,096
Code type for absolute value	binary	binary	binary
Code sequence ¹⁾	ascending	ascending	ascending
Measuring step during interpolation of the sin/cos signals (for 12 bit)	20 arc seconds	2.5 arc seconds	0.3 arc seconds
Maximum sin/cos signals interpretation error, integral non-linearity	± 288 arc seconds	± 80 arc seconds	± 45 arc seconds
Non-linearity of a sin/cos period differential non-linearity	± 144 arc seconds ²⁾	± 40 arc seconds ²⁾	± 7 arc seconds ²⁾
Output frequency	-	0 ... 65 kHz	0 ... 200 kHz
Resistance to shocks	100 g / 10 ms	100 g / 6 ms	100 g / 10 ms
Resistance to vibration	50 g / 10...2,000 Hz	50 g / 10...2,000 Hz	50 g / 10...2,000 Hz
Operating voltage range	7...12 V	7...12 V	7...12 V
Recommended supply voltage	8 V	8 V	8 V
Maximum operating current without load	< 50 mA	60 mA	80 mA
Available memory area within EEPROM 2048 ³⁾	1,792 bytes	1,792 bytes	1,792 bytes
Interface signals Process data cable = SIN, REFSIN, COS, REFCOS Parameter channel = RS 485	analog, differential digital	analog, differential digital	analog, differential digital

Safety norms

SKS/SKM36S

		SKS/SKM36S	
Safety Integrity Level ⁴⁾	-	SIL2 (EN 61800-5-2 / EN 62061)	-
Category ⁴⁾	-	3 (EN ISO 13849-1)	-
Performance Level ⁴⁾	-	PL d (EN ISO 13849-1)	-

1) For rotation of the shaft in clockwise direction when facing in the direction of "A"

2) In the nominal position ± 0.1 mm

3) When using the electronic nameplate in operative connection with numerical controls, consider the patent EP 425 912 B 2; use in operative connection with speed controllers is excluded from this rule.

4) Safety norms are only valid for motors with safely mounted encoders.

Option absolute encoders

Capacitive sensing encoder - HIPERFACE DSL®

EES / EEM37

(Single- or multi-turn encoder)



Specifications:

- Absolute position with a resolution of 131,072 steps per revolution
- Measuring of 4,096 revolutions (multi-turn)
- Programming of the position value
- HIPERFACE DSL®-interface
- Electronic type label



1) In preparation

Optische Systeme - HIPERFACE DSL®

EKS / EKM36

(Single- or multi-turn encoder)

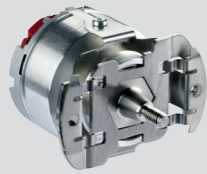

Specifications:

- Absolute position with a resolution of 262,144 steps per revolution
- Measuring of 4,096 revolutions (multi-turn)
- Programming of the position value
- HIPERFACE DSL®-interface
- Electronic type label



EFS / EFM50

(Single- or multi-turn encoder)

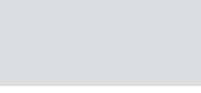

Specifications:

- Absolute position with a resolution of 8,388,608 steps per revolution
- Measuring of 4,096 revolutions (multi-turn)
- Programming of the position value
- HIPERFACE DSL®-interface
- Electronic type label



Specifications	EES/EEM37	EKS/EKM36	EFS/EFM50
Number of sin/cos periods per revolution	-	-	-
Maximum number of turns	Single EES 1 Multi EEM 4,096	Single EKS 1 Multi EKM 4,096	Single EFS 1 Multi EFM 4,096
Code type for absolute value	binary	binary	binary
Code sequence ¹⁾	ascending	ascending	ascending
Measuring step during interpolation of the sin/cos signals (for 12 bit)	-	-	-
Maximum sin/cos signals interpretation error, integral non-linearity	± 160 arc seconds ²⁾	± 80 arc seconds	± 45 arc seconds
Non-linearity of a sin/cos period differential non-linearity	-	± 40 arc seconds	± 7 arc seconds
Output frequency	-	0 ... 75 kHz (digital position value)	0 ... 75 kHz (digital position value)
Resistance to shocks	100 g / 6 ms	100 g / 6 ms	100 g / 6 ms
Resistance to vibration	50 g / 10...2,000 Hz	50 g / 10...2,000 Hz	30 g / 10...2,000 Hz
Operating voltage range	7...12 V	7...12 V	7...12 V
Recommended supply voltage	-	8 V	9 V
Maximum operating current without load	150 mA	150 mA	150 mA
Available memory area within EEPROM 2048 ³⁾	8,192 Byte	8,192 Byte	8,192 Byte
Interface signals Process data cable = SIN, REFSIN, COS, REFCOS Parameter channel = RS 485	differential, digital	differential, digital	differential, digital

Safety norms

EKS/EKM36-2

Safety Integrity Level ⁴⁾	-	SIL2 (EN 61800-5-2 / EN 62061)	-
Category ⁴⁾	-	3 (EN ISO 13849-1)	-
Performance Level ⁴⁾	-	PL d (EN ISO 13849-1)	-

1) For rotation of the shaft in clockwise direction when facing in the direction of "A"

2) System accuracy

3) When using the electronic nameplate in operative connection with numerical controls, consider the patent EP 425 912 B 2; use in operative connection with speed controllers is excluded from this rule.

4) Safety norms are only valid for motors with safely mounted encoders.

Option hall encoders

HES1-001

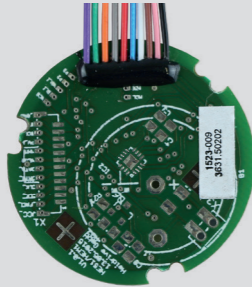

Specifications:

- Single-turn encoder with a resolution of 12 bit (interpolated 14 bit)
- SSI interface differential and single-ended
- Differential sin/cos signals with 4.5 V_{p-p}

HES1-002

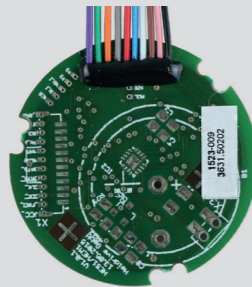

Specifications:

- Single-turn encoder with a resolution of 12 bit (interpolated 14 bit)
- SSI interface differential and single-ended
- Differential sin/cos signals with 1.0 V_{p-p}

HEM1-001

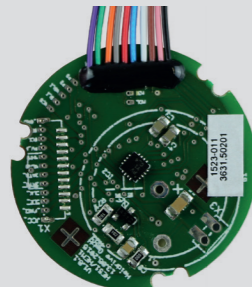

Specifications:

- Multi-turn encoder with a resolution of 32 bit (≈ 4.2 billion revolutions measurable)
- Single-turn encoder with a resolution of 12 bit (interpolated 14 bit)
- SSI interface differential and single-ended
- Differential sin/cos signals with 1.0 V_{p-p}
- External battery connector

HEM1-002

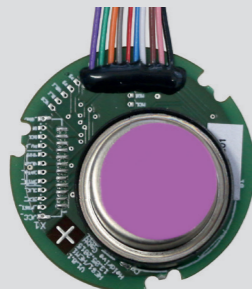

Specifications:

- Multi-turn encoder with a resolution of up to 32 bit (≈ 4.2 billion revolutions measurable)
- Single-turn encoder with a resolution of 12 bit (interpolated 14 bit)
- SSI interface differential and single-ended
- Differential sin/cos signals with 1.0 V_{p-p}
- Battery on board

HES3

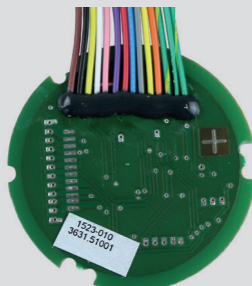

Specifications:

- Single-turn encoder with a resolution of 10 bit (interpolated 12 bit)
- Commutation and incremental signals ABZ, differential and single-ended
- Commutation signals for 2/4/6 or 8-pole motors

Specifications

(according to DIN 32878)

	HES1-001	HES1-002	HEM1-001	HEM1-002	HES3
Diameter (mm)	34.95 ± 0.05	34.95 ± 0.05	34.95 ± 0.05	34.95 ± 0.05	34.95 ± 0.05
Power supply voltage	5.0 V _{DC} ± 10%	5.0 V _{DC} ± 10%	5.0 V _{DC} ± 10%	5.0 V _{DC} ± 10%	5.0 V _{DC} ± 10%
Maximum output current	50 mA	50 mA	50 mA	50 mA	50 mA
Maximum resolution single-turn	12 bit 0.088°	12 bit 0.088°	12 bit 0.088°	12 bit 0.088°	10 bit 0.35
Maximum resolution single-turn interpolated	14 bit 0.022°	14 bit 0.022°	14 bit 0.022°	14 bit 0.022°	12 bit 0.088°
Maximum number of turns	-	-	32 bit ≈ 4.2 billion	32 bit ≈ 4.2 billion	-
Backup battery for multi-turn encoder	-	-	external	on board	-
SSI interface	differential & single ended	differential & single ended	differential & single ended	differential & single ended	-
Maximum SSI operating frequency	4 MHz	4 MHz	4 MHz	4 MHz	-
Sin/cos signals	differential	differential	differential	differential	-
Number of sin/cos periods per turn	1	1	1	1	-
Amplitude sin/cos	4.5 V _{p-p}	1.0 V _{p-p}	1.0 V _{p-p}	1.0 V _{p-p}	-
Incremental signals ABZ	-	-	-	-	differential
High-level output voltage ABZ	-	-	-	-	min. 3.8 V
Low-level output voltage ABZ	-	-	-	-	max. 0.7 V
Commutation signals	-	-	-	-	differential
Commutation high-level output voltage (U _W)	-	-	-	-	min. 3.8 V
Commutation low-level output voltage (U _W)	-	-	-	-	max. 0.7 V
ESD voltage	2 kV	2 kV	2 kV	2 kV	2 kV
Order code segment	XXM1SXXX	XXM2SXXX	XXM1MXXX	XXM2MXXX	XXM1IXXX

Option holding brake

Any HeiMotion Dynamic motor maybe equipped with a permanent-magnet DC holding brake.
The standard motors are not suitable for dynamic brakes.

Insulation class:	F (155 °C)
Maximum speed:	10,000 rpm
Voltage supply:	24 V _{DC} + 6 % / -10 %

Specifications brake	HMDo6			
	-005	-010	-015	-020
Moment of inertia motor <u>with</u> brake * [kg-cm ²]	2.47E-01	2.99E-01	4.09E-01	5.49E-01
Static braking torque [Nm]	2.0	2.0	2.0	2.0
Dynamic braking torque [Nm]	1.7	1.7	1.7	1.7
Rated input power [W]	11	11	11	11
Working voltage [V _{DC}]	24	24	24	24
Input current brake [A]	0.46	0.46	0.46	0.46
Energy rating [kJ]	580	580	580	580
Separating time brake [ms]	25	25	25	25
Brake delay [ms]	2	2	2	2
Application delay time [ms]	10	10	10	10
Weight of motor <u>with</u> brake * [kg]	1.45	1.60	1.95	2.35
Slipping time ** [s]	0.5	0.5	0.5	0.5
Idle time ** [s]	0.5	0.5	0.5	0.5
Speed ** [min ⁻¹]	200	200	200	200
Cycle quantity ** [-]	5	5	5	5

* Incl. all attachment parts

** In order to guarantee the optimum function of the brake at all times, the respective maintenance cycle (refreshment) is recommended at initial start-up and at intervals of four weeks.

Specifications brake	HMDo8				
	-020	-028	-035	-050	-060
Moment of inertia motor <u>with</u> brake * [kg-cm ²]	9.33E-01	1.20E00	1.47E00	2.00E00	2.52E00
Static braking torque [Nm]	4.5	4.5	4.5	4.5	4.5
Dynamic braking torque [Nm]	3.8	3.8	3.8	3.8	3.8
Rated input power [W]	12	12	12	12	12
Working voltage [V _{DC}]	24	24	24	24	24
Input current brake [A]	0.50	0.50	0.50	0.50	0.50
Energy rating [kJ]	580	580	580	580	580
Separating time brake [ms]	35	35	35	35	35
Brake delay [ms]	2	2	2	2	2
Application delay time [ms]	15	15	15	15	15
Weight of motor <u>with</u> brake * [kg]	2.85	3.35	3.80	4,80	6,00
Slipping time ** [s]	0.5	0.5	0.5	0.5	0.5
Idle time ** [s]	0.5	0.5	0.5	0.5	0.5
Speed ** [min ⁻¹]	100	100	100	100	100
Cycle quantity ** [-]	5	5	5	5	5

* Incl. all attachment parts

** In order to guarantee the optimum function of the brake at all times, the respective maintenance cycle (refreshment) is recommended at initial start-up and at intervals of four weeks.

The motor may not be operated with the brake applied. The brake is designed as a holding brake. An emergency stop of a running motor using the brake is permitted in exceptional cases. The number of emergency stops is limited by the moment of inertia of the entire system.

Option connector Y-Tec



Power		Signal resolver		Signal HIPERFACE®		Signal HES/M1		Signal EnDat 2.2	
Pin	Function	Pin	Function	Pin	Function	Pin	Function	Pin	Function
A	U	1	cos +	1	cos +	1	cos +	1	-
B	V	2	cos - / refcos	2	cos - / refcos	2	cos - / refcos	2	-
C	W	3	sin +	3	sin +	3	sin +	3	-
Ground.	PE	4	sin- / refsin	4	sin- / refsin	4	sin- / refsin	4	-
1	Therm. Prot. + ²⁾	5	R1 (ref +)	5	Data +	5	V _{CC} / 5 V	5	U _p
2	Therm. Prot. - ²⁾	6	R2 (ref -)	6	Data -	6	GND	6	GND / 0 V
3	Brake + ¹⁾	7	-	7	Us	7	Data +	7	Data +
4	Brake - ¹⁾	8	-	8	GND	8	Data -	8	Data -
5	-	9	Therm. Prot. + / Temp +	9	Therm. Prot. + / Temp +	9	CLK +	9	CLK +
		10	Therm. Prot. - / Temp -	10	Therm. Prot. - / Temp -	10	CLK -	10	CLK -
		11	-	11	-	11	Therm. Prot. + / Temp + ³⁾	11	Therm. Prot. +
		12	-	12	-	12	Therm. Prot. - / Temp - ⁴⁾	12	Therm. Prot. -

1) If applicable
2) Only with CKS 36, HES3 and HEM1-001

3) Battery + at HEM1-001
4) Battery - at HEM1-001

Motor connector

View mating face

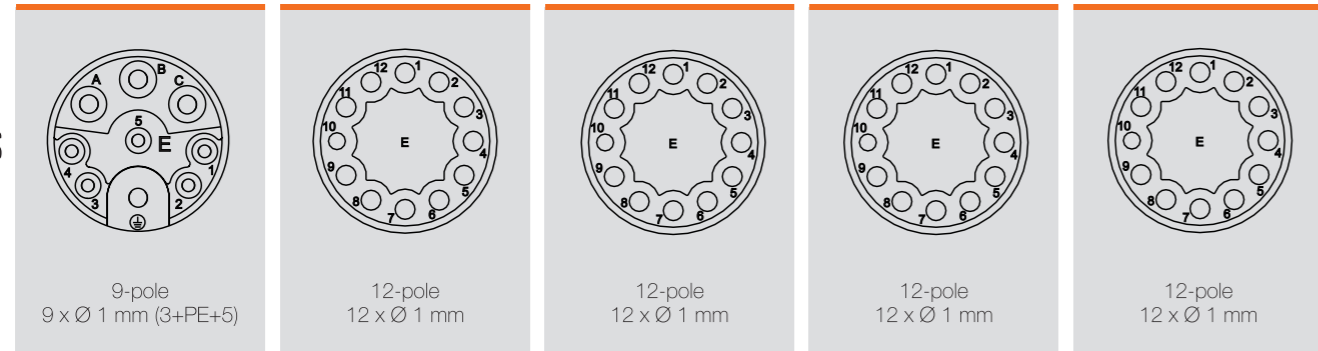

Mating connector

View mating face

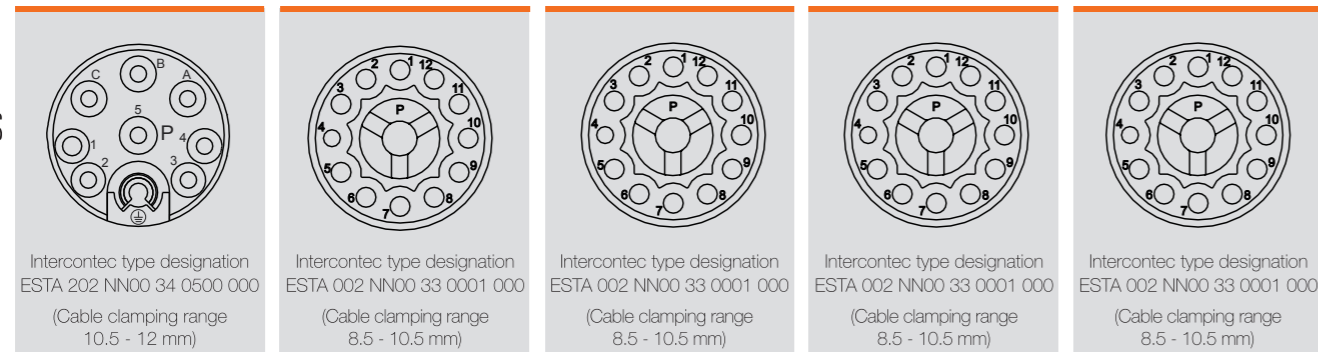

Signal CKS36		Signal HES3	
Pin	Function	Pin	Function
1	Z	1	Z
2	Z̄	2	Z̄
3	A	3	A
4	Ā	4	Ā
5	B	5	B
6	B̄	6	B̄
7	R	7	U
8	R̄	8	Ū
9	S	9	V
10	S̄	10	V̄
11	T	11	W
12	T̄	12	W̄
A	Us	A	V _{CC} / 5 V
B	GND	B	GND
C	-	C	-

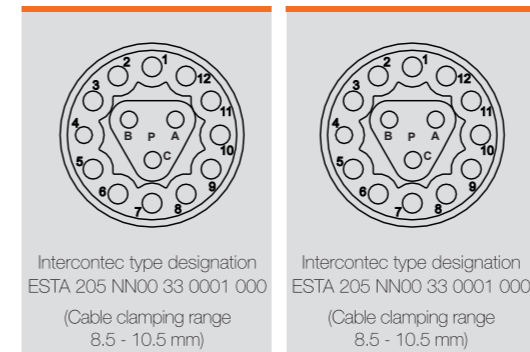
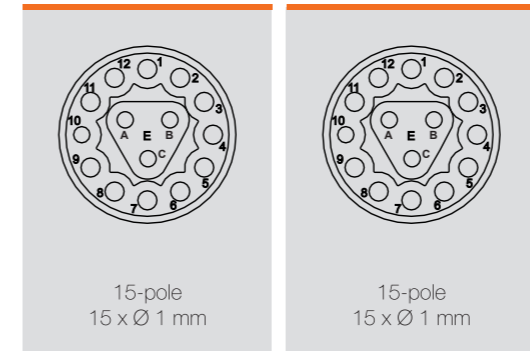

Mating connectors available with metal fittings only

Motor connector Angled receptacle Y-Tec, rotatable

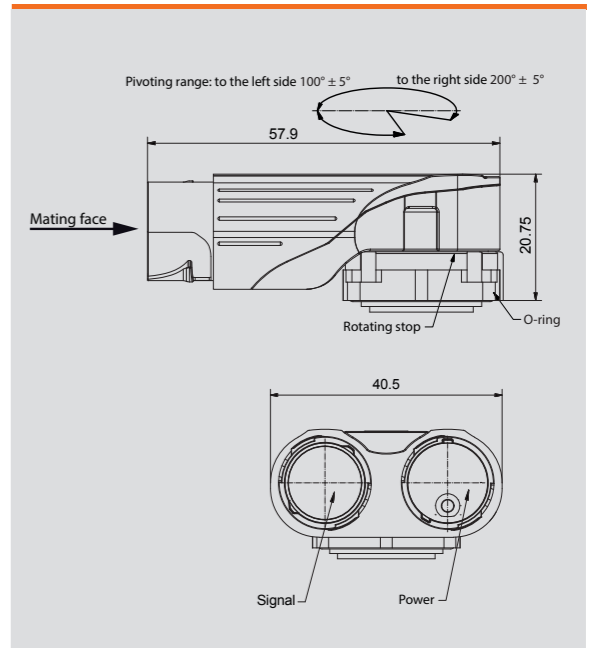

Mating connector

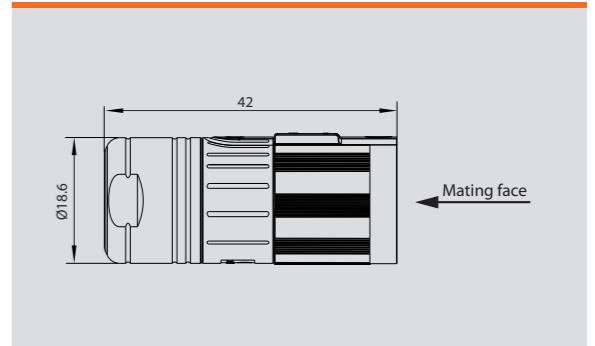

Option connector M23



Power		Signal Resolver		Signal HIPERFACE®		Signal HES/M1		Signal EnDat 2.2	
Pin	Function	Pin	Function	Pin	Function	Pin	Function	Pin	Function
A	Brake + ¹⁾	1	cos +	1	cos +	1	cos +	1	-
B	Brake - ¹⁾	2	cos - / refcos	2	cos - / refcos	2	cos - / refcos	2	-
C	Therm. Prot. +	3	sin +	3	sin +	3	sin +	3	-
D	Therm. Prot. -	4	sin - / refsln	4	sin - / refsln	4	sin - / refsln	4	-
1	U	5	-	5	-	5	V _{CC} / 5 V	5	U _p
4	V	6	R1 (ref +)	6	-	6	GND	6	GND/OV
3	W	7	R2 (ref -)	7	GND	7	Data +	7	Data +
Ground.	PE	8	-	8	-	8	Data -	8	Data -
		9	-	9	US	9	CLK +	9	Clock +
		10	-	10	Data +	10	CLK -	10	Clock -
		11	Therm. Prot. + / Temp +	11	Data -	11	Therm. Prot. + / Temp +	11	Therm. Prot. +
		12	Therm. Prot. - / Temp -	12	-	12	Therm. Prot. - / Temp -	12	Therm. Prot. -
		13	-	13	-	13	- ²⁾	13	-
		14	Therm. Prot. + / Temp +	14	Therm. Prot. + / Temp +	14	- ³⁾	14	-
		15	Therm. Prot. - / Temp -	15	-	15	-	15	-
		16	-	16	-	16	-	16	-
		17	-	17	-	17	-	17	-

1) If applicable
2) Battery + at HEM1-001
3) Battery - at HEM1-001

Motor connector

View mating face

8-pole 4 x Ø 2 mm (3+PE) + 4 x Ø 1 mm	12-pole 12 x Ø 1 mm, 0° coded	17-pole 17 x Ø 1 mm, 0° coded	17-pole 17 x Ø 1 mm, 0° coded	17-pole 17 x Ø 1 mm, 0° coded

Mating connector

View mating face

Intercontec type designation BSTA 078 NN00 42 0100 000 (Cable clamping range 9.5-14.5 mm)	Intercontec type designation ASTA 013 NN00 41 0100 000 (Cable clamping range 6-10 mm)	Intercontec type designation ASTA 014 NN00 41 0100 000 (Cable clamping range 6-10 mm)	Intercontec type designation ASTA 014 NN00 41 0100 000 (Cable clamping range 6-10 mm)	Intercontec type designation ASTA 014 NN00 41 0100 000 (Cable clamping range 6-10 mm)

Signal CKS36		Signal HES3	
Pin	Function	Pin	Function
1	Z	1	Z
2	Z̄	2	Z̄
3	A	3	A
4	Ā	4	Ā
5	B	5	B
6	B̄	6	B̄
7	R	7	U
8	R̄	8	Ū
9	S	9	V
10	S̄	10	V̄
11	T	11	W
12	T̄	12	W̄
13	Us	13	V _{CC} / 5 V
14	GND	14	GND
15	Therm. Prot. +	15	Therm. Prot. +
16	Therm. Prot. -	16	Therm. Prot. -
17	-	17	-

17-pole 17 x Ø 1 mm, 0° coded	17-pole 17 x Ø 1 mm, 0° coded

Intercontec type designation ASTA 014 NN00 41 0100 000 (Cable clamping range 6-10 mm)	Intercontec type designation ASTA 014 NN00 41 0100 000 (Cable clamping range 6-10 mm)

Motor connector

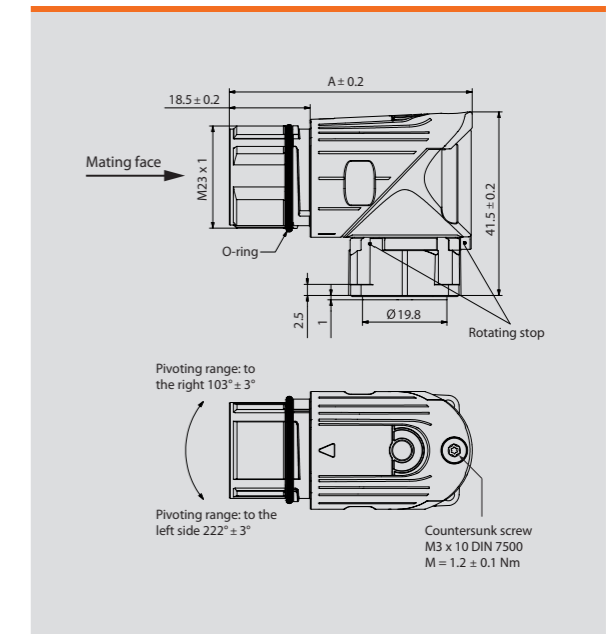

Mating connector

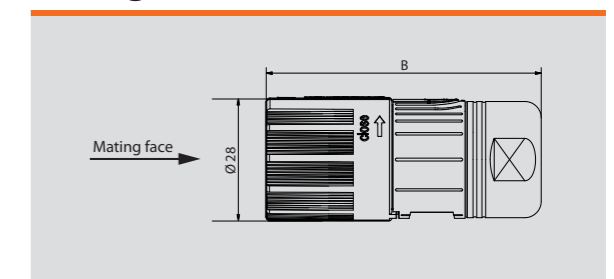

Connector type	A	B
Signal	55.6	59
Power	55.3	78

■ Option connectors for one cable solution

I-Tec connector

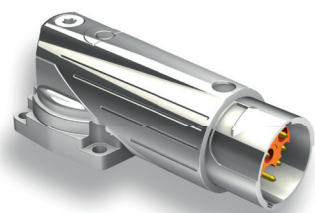

Power / Signal

Pin	Function
A	U
B	V
C	W
Grounding	PE
1	U _s (DSL +)
2	GND (DSL -)
3	Brake + *
4	Brake - *
5	-

Motor connector

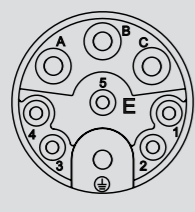

9-pole
9 x Ø 1 mm (3+PE+5)

Mating connector

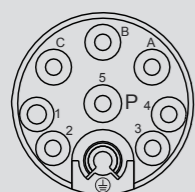

Intercontec type designation
ESTA 202 NN00 34 0500 000
(Cable clamping range 10.5 - 12 mm)

* If available

Motor connector

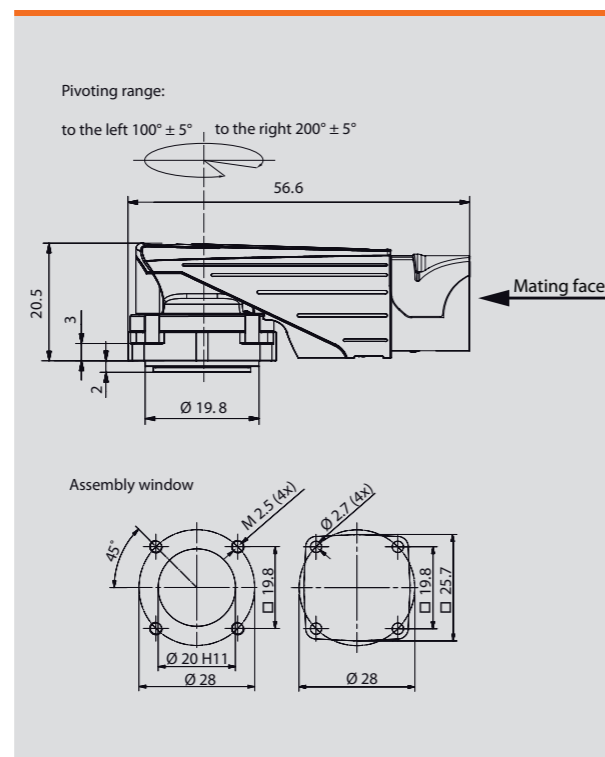

Mating connector

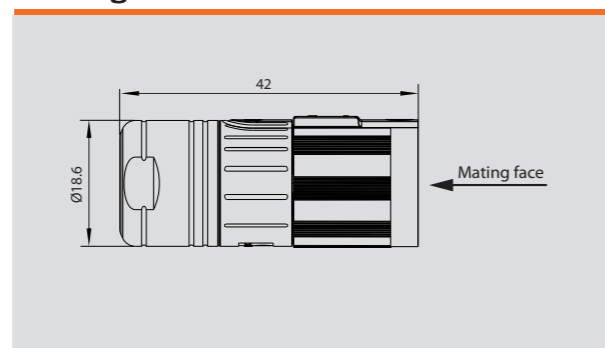

M23 connector



Power / Signal

Pin	Function
A	Brake + *
B	Brake - *
C	U _s (DSL+)
D	GND (DSL-)
1	U
4	V
3	W
Grounding	PE

Motor connector

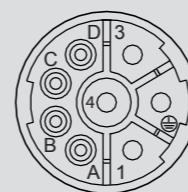

8-pole
4 x Ø 2mm (3+PE) + 4 x Ø 1mm

Mating connector

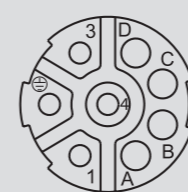

Intercontec type designation
BSTA 078 NN00 42 0100 000
(Cable clamping range 9.5 - 14.5 mm)

* If available

Motor connector

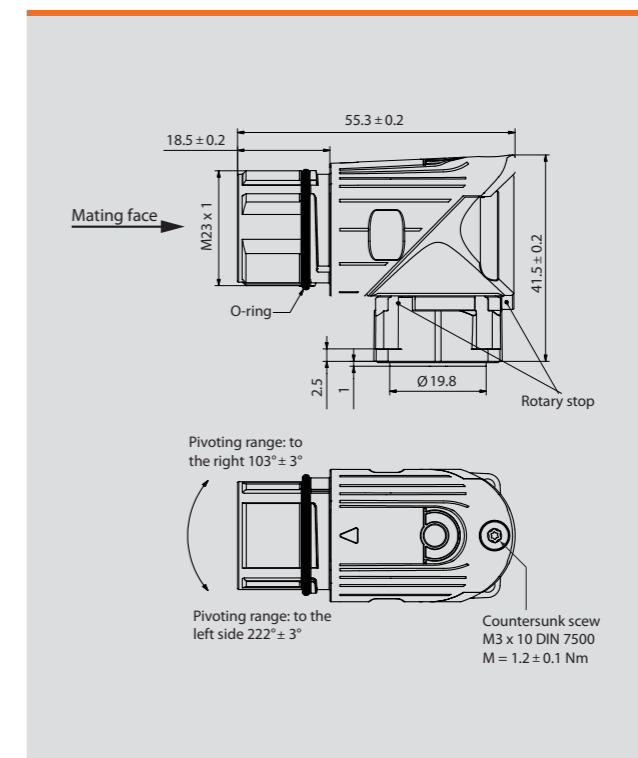

Mating connector

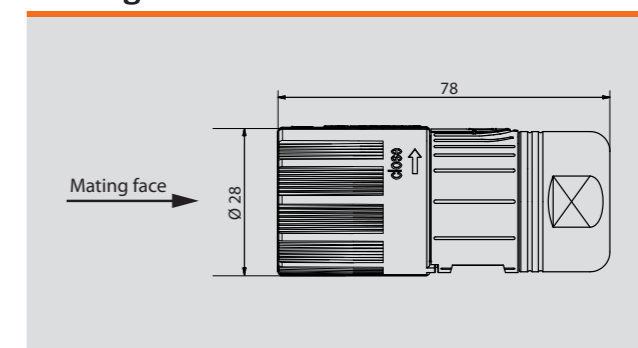

HCD servo drive, 230 V_{AC}



Specifications servo drive

Type	Supply voltage	DC bus voltage	Output Voltage	Continuous output current	Maximum output current	Rated power	Order Code
	[V _{AC}]	[V]	[V _{rms}]	[A _{rms}]	[A _{rms}]	[W]	
HCD	1 x 230	320	3 x 0 - 230	4	8	800	HCD2-004-0011-00

Switch frequency [kHz] 4, 8, 12, 16 (Factory setting 8 kHz)
 Power rating [kVA] 1.84
 Cable cross-section [mm²] 0.2...1.5
 Mains frequency [Hz] 50 / 60 ± 10 %

The small 4-Q-servo-drive HCD has been specially developed for cost-sensitive and simple control tasks, such as speed-, torque-, and position-controlled applications. Its drive control uses digital- and analogue inputs, PLC Motion or fieldbus (CANopen). Depending on the motor, the HCD has an output power up to 800 W in S1 mode. Our specially developed HES/HEM encoder systems is suitable for this purpose.

Dimensions

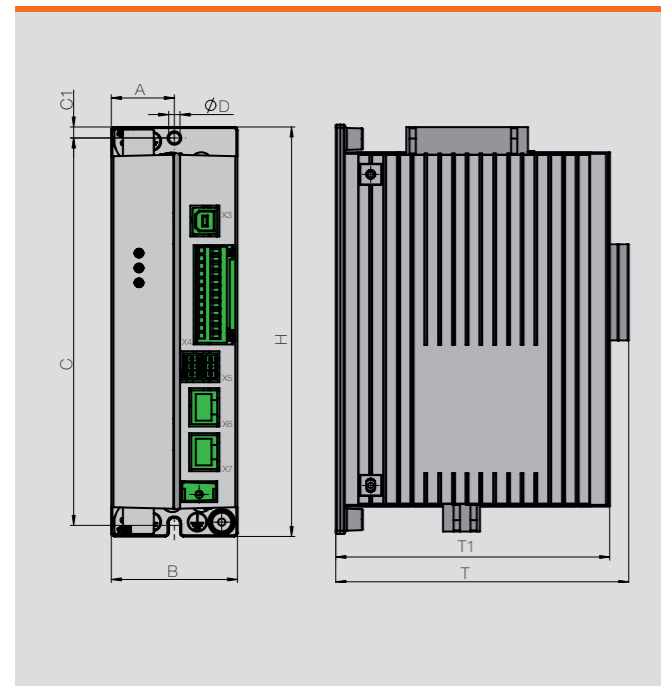

Connection plan

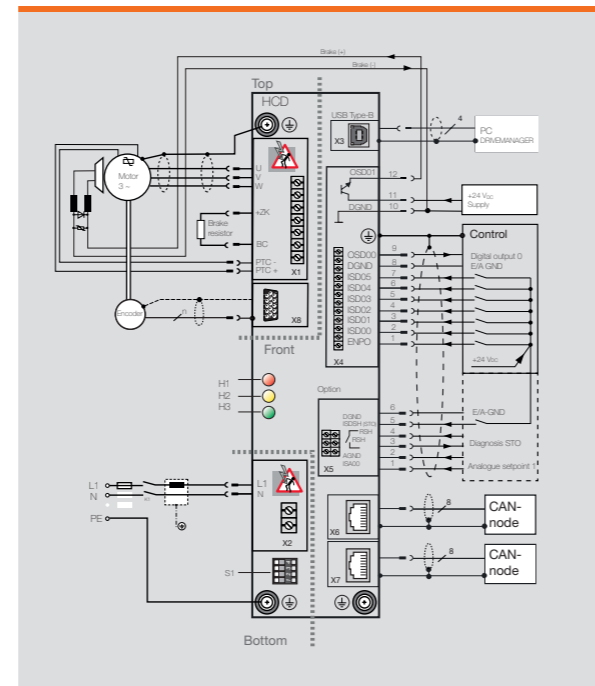

Connections

Type	Connection	Function
H1, H2, H3	Light emitting diodes (integrated)	Device status display
S1	DIP circuit	Setting the CAN address
X2	Plug-in terminal (2-pole)	Single phase supply
PE	PE connection pins	Protective grounding
X4	Plug-in terminal (12-pole)	6 digital inputs 1 digital output Interface for motor brake
X1	Plug-in terminal (7-pole)	Motor phases (U/V/W) Brake resistor (+ZK, BC) Temperature monitoring (PTC+, PTC-)
X3	USB connector (Type-B)	Connection for PC with DriveManager
X6/ X7	2x RJ45 connector	CANopen interface
X8	D-Sub connector (15-pole)	Interface for rotary encoder
X5 (opt.)	Plug-in terminal (6-pole)	Connections for STO functionality (ISDSH, RSH)
X5 (opt.)	Plug-in terminal (6-pole)	Analogue input (ISA00), resolution 10-bit ADC

Ambient conditions

Humidity in operation:	relative humidity 5 - 85 % without condensation
Ambient temperature in operation:	+ 5 °C ... - + 40 °C
Storage humidity:	relative humidity 5 - 95 %
Storage temperature:	- 25 °C ... + 55 °C
Protection class:	IP00
Installation altitude:	up to 1,000 m, up to 2,000 meter with power reduction

Supported encoder systems

SSI, TTL

Interface

CANopen (CiA 402)

Functions

- PLC Motion
- Speed control
- Torque control
- Positioning
- Ramp generator
- Integrated mains filter
- Integrated braking chopper
- UL approval*: Certified according to UL 508c
- Safety function STO

* Valid as long as the prescribed operating conditions are observed.

HCE servo drive, 230 / 400 V_{AC}



Specifications servo drive

Type	DC bus voltage	Supply voltage	Continuous output current	Maximum output current	Frame size
	[V]	[V]	[A _{rms}]	[A _{rms}]	
HCE 0.375 kW	325	1 x 230	2.4	4.3	size 1 - CP
HCE 0.75 kW	325	1 x 230	4.0	7.2	size 1 - CP
HCE 0.75 kW	560	3 x 400	2.2	4	size 2 - CP
HCE 1.5 kW	325	1 x 230	7.1	12.8	size 2 - W
HCE 1.5 kW	560	3 x 400	4.1	7.4	size 2 - W
HCE 2.2 kW	560	3 x 400	5.7	10.3	size 2 - W
HCE 3.0 kW	560	3 x 400	7.8	14	size 3 - W
HCE 4.0 kW	560	3 x 400	10	18	size 3 - W
HCE 5.5 kW	560	3 x 400	14	25	size 4 - W
HCE 7.5 kW	560	3 x 400	17	31	size 4 - W
HCE 11 kW	560	3 x 400	24	43	size 5 - W
HCE 15 kW	560	3 x 400	32	58	size 5 - W
HCE 22 kW ²⁾	560	3 x 400	45	90	size 6 - W
HCE 30 kW ²⁾	560	3 x 400	60	120	size 6 - W
HCE 37 kW ²⁾	560	3 x 400	72	144	size 6 - W

1) 1,8 x I_N für 30s rotary field frequency 0 - 400 Hz / mains voltage
 1 x 230 V - 20 % + 15 % / mains voltage
 3 x 400 V - 15 % + 15 % mains frequency
 50 / 60 Hz ± 10 %
 2) Upon request

Connections / inputs and outputs

Type	Connection	Function
X1	Plug-in terminal (12-pole)	Mains supply (L1/L2/L3/PE) Mains supply (L1/N/PE) DC-link (L+/L-) Motor phases (U/V/W/PE) Brake resistor (L+/RB)
X2	Plug-in terminal (2 x 12-pole)	Safe Stop with relay output 8 digital inputs 2 analog inputs (10-bit ADC) 3 digital outputs 1 relay (24 V / 1 A)
X3	Plug-in terminal (2-pole)	Temperature monitoring (PTC / KTY / Klixon)
X4	D-sub connector (9-pole)	RS232 interface
X5	D-sub panel connector (9-pole)	CANopen interface
X6	D-sub connector (9-pole)	Interface for resolver
X7	D-sub connector (15-pole)	Interface for rotary encoders (TTL / SSI / HIPERFACE)
X8	Plug-in terminal (2-pole)	Expansion slot for option module
X9	Plug-in terminal (2-pole)	Interface for motor brake

size 1 - Cold Plate

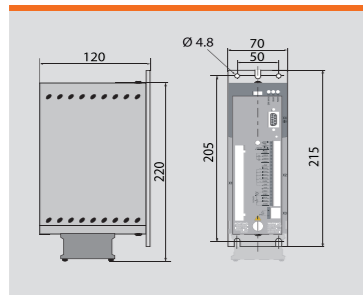

size 2 - Cold Plate

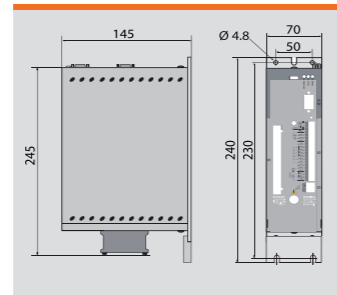

size 2 - Wall mounted

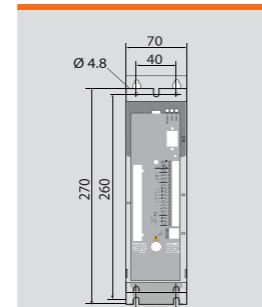

size 3 - Wall mounted

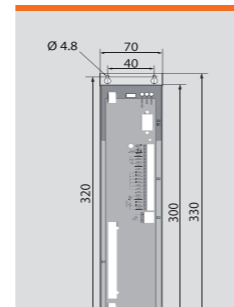

size 4 - Wall mounted

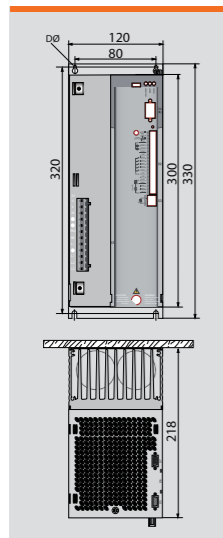

size 5 - Wall mounted

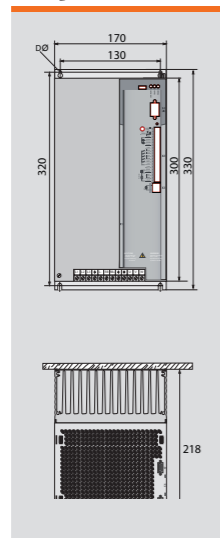

size 6 - Wall mounted

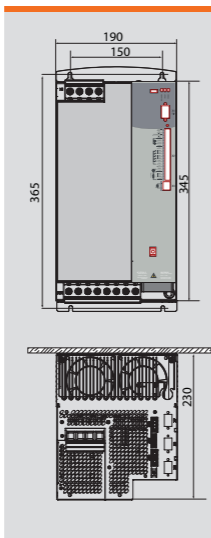

size 2 - Wall mounted

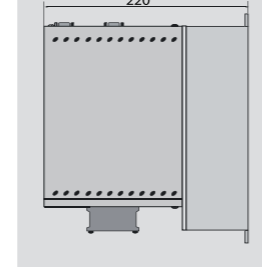

size 3 - Wall mounted

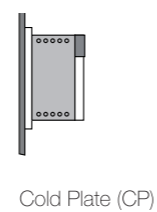
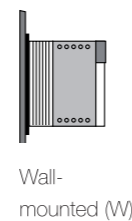
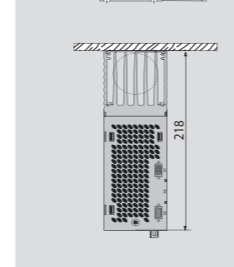

Ambient conditions

Ambient temperature in operation:	- 10 °C ... + 40 °C
Storage temperature:	- 25 °C ... + 55 °C
Operating and storage humidity:	< 90 % relative humidity (without condensation)
Protection class:	IP20
Installation altitude:	up to 1,000 m
Vibration:	according to IEC 60068-2-6 / 29

Supported encoder systems

Resolver, Incremental encoder, SSI absolute encoder, HIPERFACE® encoder

Interface

CANopen (CiA 402), RS232

Functions

- SMARTCARD for data backup and commissioning
- Radio interference filters (RFI) up to 7.5 kW
- Brake driver
- PLC Motion
- DriveManager software
- Online position profile generator
- Integrated braking resistor
- Electronic cam
- Sequenced driving set positioning
- Safe stop according to EN 954-1, category 3

HCF servo drive, 24 to 48 V_{DC}



Specifications servo drive

Typ	Supply voltage [V _{DC}]	DC bus voltage [V _{DC}]	Output voltage [V _{rms}]	Continuous output current [A _{rms}]	Maximum output current [A _{rms}]	Rated power [W]	Order code
HCF	24 - 48	24 - 48	3x0 - 33	8	16	240	HCF0-008-1x.x.-0

1) 2x rated current for 30 sec

Switch frequency [kHz] 8, 16 (Factory setting 8 kHz)

Power rating [kVA] 0.55

Cable cross-section [mm²] 1.5...2.5

Logic supply [V_{DC}] 24

The HCF servo drive is a cost-optimized, DC powered 24 V or 48 V motor controller for use in the demanding world of precision automation technology. The HCF features high precision positioning functionality, a sturdy mechanical design, CANopen CiA 402 support, safe stop according to Category 3 of IEC 954-1, and much more.

Dimensions (mm)

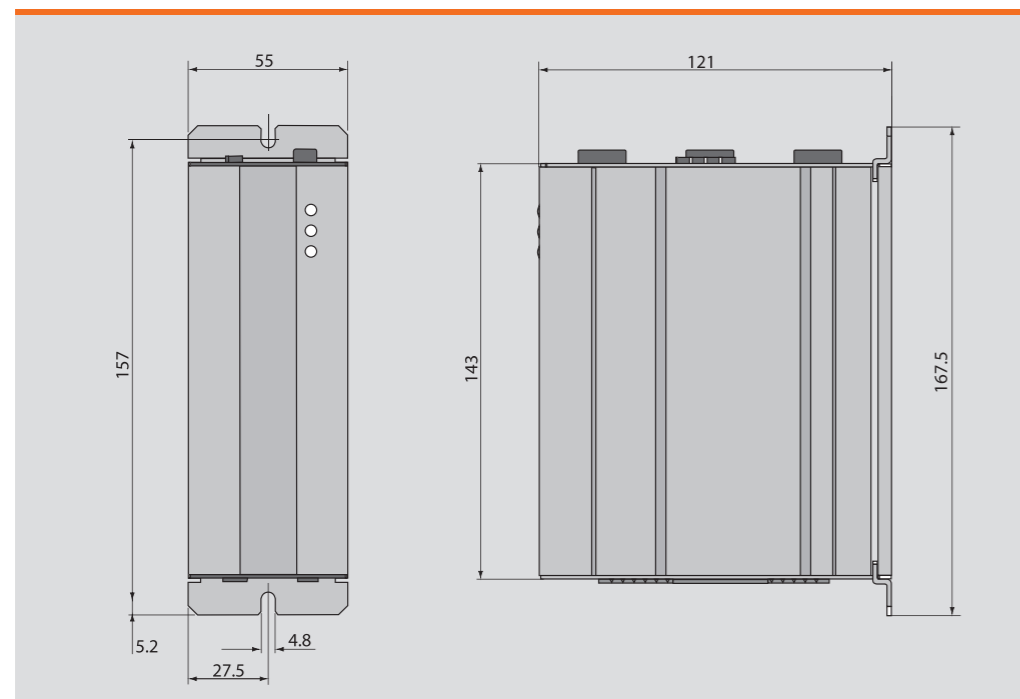

Connections / inputs and outputs

Type	Connection	Function
X1	Plug-in terminal (6-pole)	DC supply (L+ / L-) Brake resistor (L+ / RB)
X2	Plug-in terminal (2 x 10-pole)	Safe Stop with relay output 8 digital inputs 2 analog inputs 10-bit ADC 3 digital outputs 1 relay output (24 V / 1 A) Logic power supply
X3	Plug-in terminal (4-pole)	Motor phases (U/V/W/PE)
X4	D-sub connector (9-pole)	RS232 interface
X5	D-sub panel connector (9-pole)	CANopen interface
X6	D-sub connector (15-pole)	Interface for rotary encoders with temperature monitoring (PTC / KTY / Klixon)
S1	Rotary code switch	Setting the CANopen address

Ambient conditions

Ambient temperature in operation:	- 10 °C ... + 40 °C
Storage temperature:	- 25 °C ... + 55 °C
Operating and storage humidity:	15 ... 85 % relative humidity (without condensation)
Protection class:	IP20
Installation altitude:	up to 1,000 m

Supported encoder systems

Resolver, Incremental encoder, SSI absolute encoder

Interface

CANopen (CiA 402), RS232

Functions

- Brake driver
- PLC Motion
- DriveManager software
- Online position profile generator
- Integrated braking resistor
- Electronic cam
- Sequenced driving set positioning
- Safe stop according to EN 954-1, category 3

HCJ drive, 230 / 400 V_{AC}



Specifications servo drive

Typ	DC bus voltage	Input voltage	Continuous output current I_N	Maximum output current I_{MAX}	Frame size
	[V]	[V]	[A _{rms}]	[A _{rms}]	
HCJ22.003	325	1 / 3 x 230	3	9	size 2
HCJ24.002	560	3 x 400	2	6	size 2
HCJ22.006	325	1 / 3 x 230	5.9	17.7	size 3
HCJ24.004	560	3 x 400	3.5	10.5	size 3
HCJ22.008	325	1 / 3 x 230	8	24	size 4
HCJ24.007	560	3 x 400	6.5	19.5	size 4
HCJ24.012	560	3 x 400	12	36	size 5
HCJ24.016	560	3 x 400	16	48	size 5

Mains frequency [Hz] 50 / 60 ± 10 %

size 2/3/4

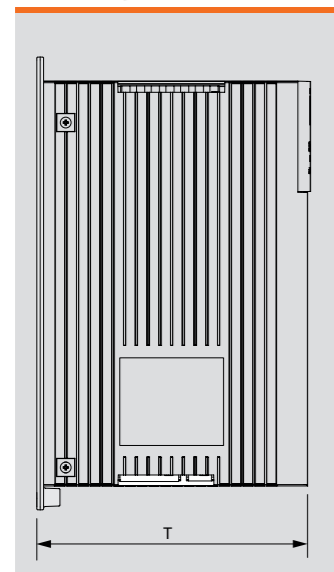

size 2/3

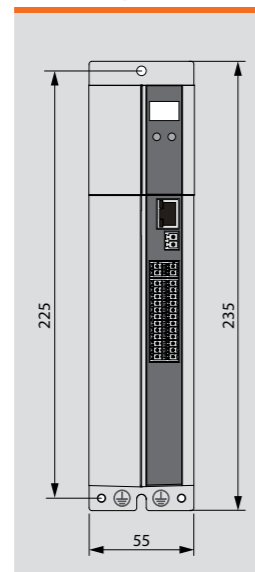

size 4

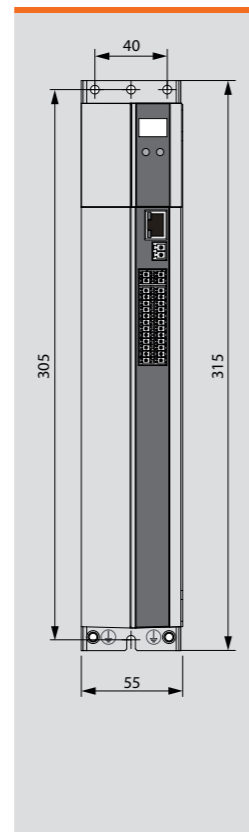

size 5

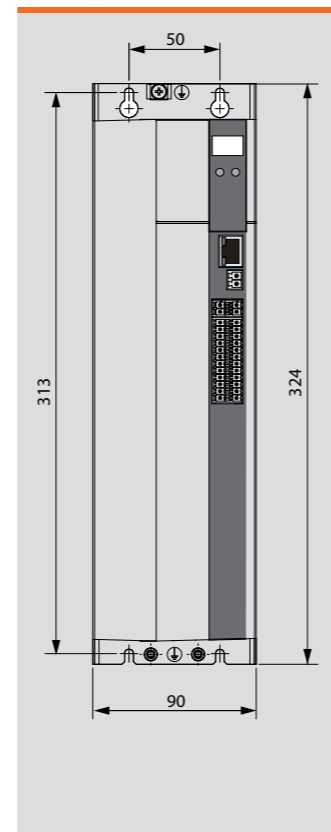

Type	T	Weight
size 2	142 mm	1.0 kg
size 3	189 mm	1.5 kg
size 4	235.5 mm	2.8 kg
size 5	235.5 mm	5.5 kg / 5.9 kg

Connections / inputs and outputs

Connection	Name	Function
X1	Plug-in terminal (7-pole)	Motor phases (U/V/W/PE) DC-link (L+/L-) Brake resistor (L+/RB)
X2	Plug-in terminal (2-pole)	Logic supply + 24 V _{DC}
X3	Plug-in terminal (4-pole)	Mains supply (L1/L2/L3/PE)
X4	Plug-in terminal (2x 10-pole)	7 digital inputs 2 analog inputs (10-bit ADC) 3 digital outputs 1 relay (24 V / 1 A) diagnosis STO
X5	Plug-in terminal (2-pole)	Temperature monitoring (PTC / KTY / Klixon)
X6	D-sub connector (9-pole)	Interface for resolver
X7	D-sub connector (15-pole)	Interface for rotary encoders (TTL / SSI / HIPERFACE / ENDAT)
X9	RJ-45 connector	Interface for Ethernet
X13	Plug-in terminal (4-pole)	Interface for motor brake
Option 1	Connector (depending on module)	Fieldbus interface e.g. CANopen, EtherCAT, SERCOS, ...
Option 2	Connector (depending on module)	Encoder interface e.g. second (safe) encoder, Encoder simulation, TwinSync, axis monitoring, ...

Ambient conditions

Ambient temperature in operation:	- 10 °C ... + 40 °C
Storage temperature:	- 25 °C ... + 55 °C
Operating and storage humidity:	< 85 % relative humidity (without condensation)
Protection class:	IP20 except clamps (IP00)
Installation altitude:	up to 1,000 m

Supported encoder systems

Resolver, HIPERFACE® encoder, HIPERFACE DSL® encoder, Incremental encoder, SSI absolute encoder, EnDat 2.2 encoder

Interface

CANopen (CiA 402), Ethernet (parameterization via DriveManager software)

Optional: EtherCAT, SERCOS III, Profibus DP or Profinet IRT

Functions

- PLC Motion
- Brake driver
- Sequenced driving set positioning
- Online position profile generator
- DriveManager software
- Integrated braking resistor (size 3+4)
- Safe stop according to EN 954-1, category 3
- Radio interference filters (RFI) up to 7.5 kW
- Electronic cam

Technical data subject to change! Last changes: 12/2020



Heidrive GmbH

Starenstraße 23
93309 Kelheim

Phone +49 9441/707-0
Fax +49 9441/707-259

info@heidrive.de
www.heidrive.de